

Fuji Switching Power Supply Control IC

Power Factor Correction

FA5695

Application Note

April-2011
Fuji Electric Co., Ltd.

WARNING

1. This Data Book contains the product specifications, characteristics, data, materials, and structures as of Apr. 2011. The contents are subject to change without notice for specification changes or other reasons. When using a product listed in this Data Book, be sure to obtain the latest specifications.
2. All applications described in this Data Book exemplify the use of Fuji's products for your reference only. No right or license, either express or implied, under any patent, copyright, trade secret or other intellectual property right owned by Fuji Electric Co., Ltd. is (or shall be deemed) granted. Fuji makes no representation or warranty, whether express or implied, relating to the infringement or alleged infringement of other's intellectual property rights which may arise from the use of the applications described herein.
3. Although Fuji Electric is enhancing product quality and reliability, a small percentage of semiconductor products may become faulty. When using Fuji Electric semiconductor products in your equipment, you are requested to take adequate safety measures to prevent the equipment from causing a physical injury, fire, or other problem if any of the products become faulty. It is recommended to make your design fail-safe, flame retardant, and free of malfunction.
4. The products introduced in this Data Book are intended for use in the following electronic and electrical equipment which has normal reliability requirements.
 - Computers ▪OA equipment ▪Communications equipment (terminal devices)
 - Measurement equipment ▪Machine tools ▪Audiovisual equipment ▪Electrical home appliance
 - Personal equipment ▪Industrial robots etc.
5. If you need to use a product in this Data Book for equipment requiring higher reliability than normal, such as for the equipment listed below, it is imperative to contact Fuji Electric to obtain prior approval. When using these products for such equipment, take adequate measures such as a backup system to prevent the equipment from malfunctioning even if a Fuji's product incorporated in the equipment becomes faulty.
 - Transportation equipment (mounted on cars and ships) ▪Trunk communications equipment
 - Traffic-signal control equipment ▪Gas leakage detectors with an auto-shut-off feature
 - Emergency equipment for responding to disasters and anti-burglary devices ▪Safety devices
6. Do not use products in this Data Book for the equipment requiring strict reliability such as (without limitation)
 - Space equipment ▪Aeronautic equipment ▪Atomic control equipment
 - Submarine repeater equipment ▪Medical equipment
7. Copyright © 1995 by Fuji Electric Co., Ltd. All rights reserved. No part of this Data Book may be reproduced in any form or by any means without the express permission of Fuji Electric.
8. If you have any question about any portion in this Data Book, ask Fuji Electric or its sales agents before using the product. Neither Fuji nor its agents shall be liable for any injury caused by any use of the products not in accordance with instructions set forth herein.

CONTENTS

1.	Description	4
2.	Features	4
3.	Outline	4
4.	Block diagram	5
5.	Pin assignment	5
6.	Ratings and characteristics	6 - 8
7.	Characteristic curves	9 - 10
8.	Outline of circuit operation	11 - 12
9.	Description of each circuit block	13 - 15
10.	Descriptions of use for each pin	16 - 20
11.	Advice for design	20 - 21
12.	Example of application circuit	21

Note

- The contents are subject to change without notice for specification changes or other reasons.
- Parts tolerance and characteristics are not defined in all application described in this Date book. When design an actual circuit for a product, you must determine parts tolerance and characteristics for safe and economical operation.

1. Description

FA5695 is power-factor correction converter IC operating in critical conduction mode. It realizes low power consumption by using high voltage CMOS process. It is equipped with many fault protection functions such as FB short-circuit detection circuit and double OVP function.

2. Features

- Very Low Standby Power by disusing Input Voltage Detection Resistors
- High-precision over current protection : $0.6V \pm 5\%$
- Improved power efficiency at light load due to Maximum Frequency Limitation
- No Audible Noise at Startup
 - Soft-Startup and Soft-OVP functions
- Low current consumption by CMOS process
 - Start-up : $80\mu A(\text{max.})$, Operating : $2\text{mA}(\text{typ.})$
- Enabled to drive power MOSFET directly
 - Output peak current, source : 1000mA , sink : 1000mA
- Protects the output electrolytic capacitor by the double OVP function, even if a fault happen in the output detection.
- Open/short protection at feedback (FB) pin
- Under-voltage Lockout: 13V ON / 9V OFF
- Restart timer
- Standby function
- 8-pin package (SOP)

3. Outline

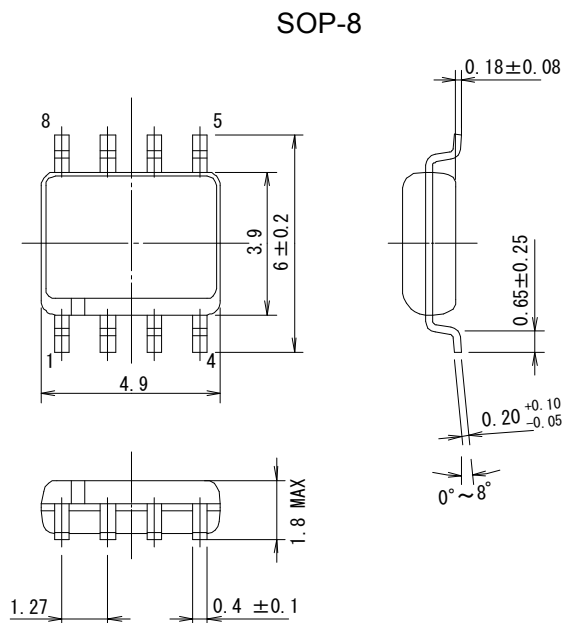

4. Block diagram

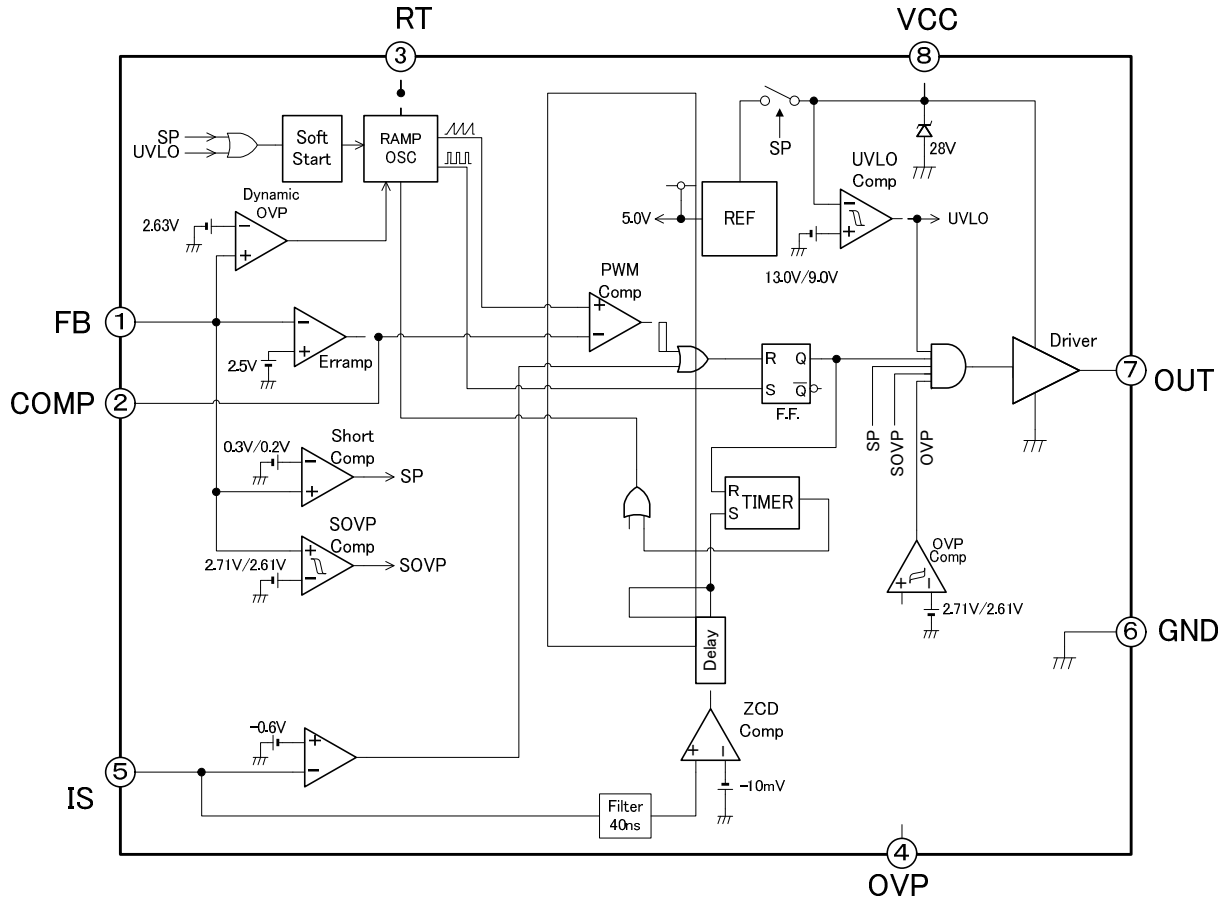

5. Pin assignment

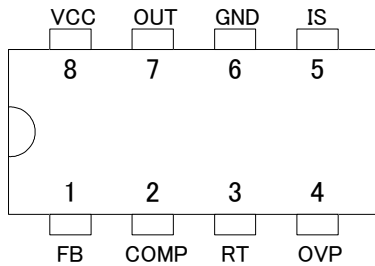

Pin No.	Pin symbol	Function	Description
1	FB	Feedback Voltage Input	Input for monitoring PFC output voltage
2	COMP	Compensation	Output of error amplifier
3	RT	Set Maximum on time	Set Maximum on time by connecting resistor
4	OVP	Over voltage detection	Monitor the output of converter and protects from over voltage
5	IS	Current Sense Input	Input for sensing current
6	GND	Ground	Ground
7	OUT	Output	Output for driving a power MOSFET
8	VCC	Power Supply	Power supply for IC

6. Ratings and characteristics

The contents are subject to change without notice. When using a product, be sure to obtain the latest specifications.

(1) Absolute Maximum Ratings

Item	Symbol	Ratings	Unit
VCC pin current	Ivcc	(TBD)	mA
Supply Voltage	Vcc	28	V
Output Current	Io	+1000 -1000	mA mA
Input voltage (FB,COMP,RT,OVP)	Vinfb, Vincomp, Vinrt, Vinovp	-0.3 to 5	V
Input voltage (IS)	Vinis	-5 to 0.3	V
Input voltage (IS:when AC on and below 10ms)	Vinis_vin	-10 to 0.3	V
Input current (FB, COMP, RT, OVP, IS)	Iinfb, Iincomp, Iinrt, Iinovp	+/- 100	uA
Input current (IS:when AC on and below 10ms)	Iinis_vin	-20	mA
Power dissipation	Pd	625	mW
Operating Ambient Temperature	Ta	-40 to +105	°C
Operating Junction Temperature	Tj	+150	°C
Storage Temperature	Tstg	-40 to +150	°C

Maximum dissipation curve

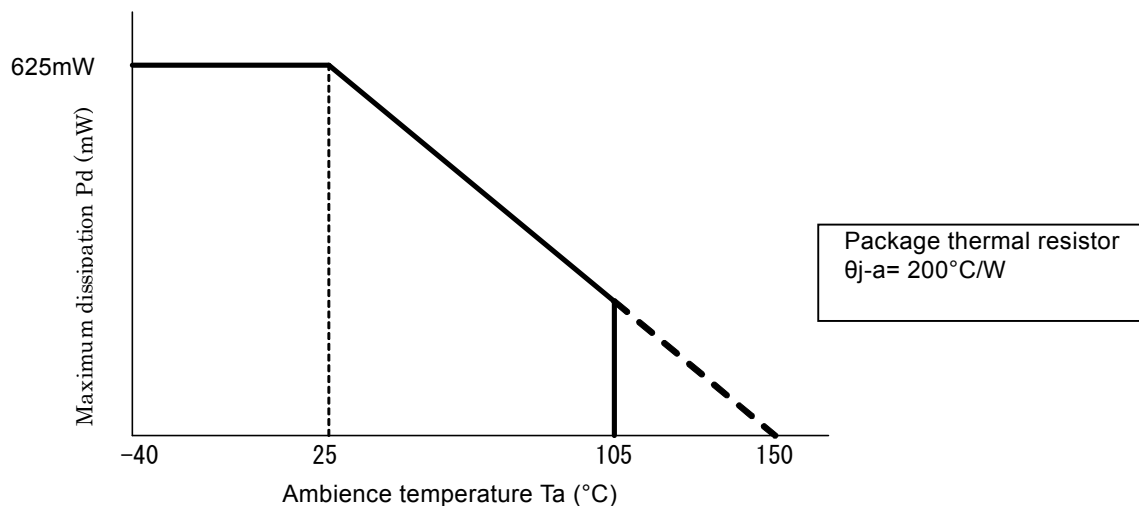

(2) Recommended Operating Conditions

Item	Symbol	MIN	TYP	MAX	Unit
Supply Voltage	Vcc	10	12	26	V
VCC pin electrolytic capacitor	Cvcce	10	-	-	uF
VCC pin ceramic capacitor	Cvccc	0.1	-	-	uF
RT pin resistance	Rrt	20	82	150	kΩ
FB, OVP pin resistance	Rfb, Rovp	-	-	8	MΩ
IS pin filter resistance	Risf	-	-	100	Ω

(3)Electrical Characteristics (Unless otherwise specified, Ta=25°C, Vcc=12V, Vfb=1.0V, Vcomp=5.0V, Rrt=82kΩ, Vovp=1.0V, Vis=100mV)

ERROR AMPLIFIER (FB,COMP Pin)

Item	Symbol	Condition	MIN	TYP	MAX	Unit
Voltage Feedback Input Threshold	Vfb		2.465	2.500	2.535	V
Line Regulation	Regline	Vcc=10V to 26V	-20	-10	-	mV
Temperature stability	VdT	Tj=-30°C to +85°C		±0.5		mV/°C
Transconductance	Gm		50	75	100	umho
Output current at startup	Io ss	Source:V(FB)=1.0V	-20	-40	-60	uA
Output Current	Io	Source:V(FB)=1.0V Sink:V(FB)=4.0V	-40 30	-60 50	-80 70	uA

RAMP OSCILLATOR (RT Pin)

Item	Symbol	Condition	MIN	TYP	MAX	Unit
Maximum on range	Tonmax	V(COMP)=5.0V V(FB)=Vfb	24	30	36	Us
Maximum on range (Soft start)	Tonmax_soft-start	V(COMP)=5.0V V(FB)=1.0V	18	24	30	us
Maximum oscillating frequency	Fmax	V(COMP)=1.0V	340	400	460	kHz
RT output voltage	Vrt		0.90	1.15	1.40	V

PWM comparator (COMP Pin)

Item	Symbol	Condition	MIN	TYP	MAX	Unit
Input threshold voltage	Vthcomp		0.6	0.7	0.8	V

SOFT START (FB Pin)

Item	Symbol	Condition	MIN	TYP	MAX	Unit
Soft start cancellation voltage	Vthsoft	V(COMP)=5.0V Ton>Tonmax*90%		0.94*Vfb		V

OVERVOLTAGE COMPARATER (FB Pin)

Item	Symbol	Condition	MIN	TYP	MAX	Unit
Static OVP threshold voltage	VsovpH	V(FB)=2.5V→3.0V	1.060*Vfb	1.080*Vfb	1.095*Vfb	V
	VsovpL	V(FB)=3.0V→2.5V	1.020*Vfb	1.040*Vfb	1.060*Vfb	V
	VsovpPhys	VsovpH-VsovpL	0.030*Vfb	0.040*Vfb	0.060*Vfb	V
Dynamic OVP threshold voltage	Vdovp	V(FB)=2.5V→3.0V Ton=Tonmax*70%	1.025*Vfb	1.050*Vfb	1.075*Vfb	V

FB SHORT COMPARATOR (FB Pin)

Item	Symbol	Condition	MIN	TYP	MAX	Unit
Input threshold voltage	Vthfb		0.1	0.3	0.5	V
Pull-up current	Ipullup	V(FB)=2.5V	1.2	1.8	2.4	uA

CURRENT SENSE COMPARATOR (IS Pin)

Item	Symbol	Condition	MIN	TYP	MAX	Unit
IS threshold voltage	Vthis		-0.58	-0.60	-0.62	V
IS threshold voltage temperature characteristics	Vthisdt	Tj=-30°C to +85°C	-1.5		1.5	%
Output delay	Tphl		-	200	500	ns
Zero current detection voltage	Vzcd		-15.0	-10.0	-5.0	mV
Zero current detection delay	Tzcd		0.3	0.9	1.5	us

OUTPUT (OUT Pin)

Item	Symbol	Condition	MIN	TYP	MAX	Unit
Output voltage (L)	Vol	Isink=200mA	-	1.2	3.3	V
Output voltage (H)	Voh	Isouce=200mA	7.8	8.4		V
Output rise time	Tr	CL=1.0nF	-	50	120	ns
Output fall time	Tf	CL=1.0nF	-	25	100	ns

Restart timer

Item	Symbol	Condition	MIN	TYP	MAX	Unit
delay time	Tdly			30		μs

Low voltage protection (VCCPin)

Item	Symbol	Condition	MIN	TYP	MAX	Unit
ON threshold voltage	Von		11.5	13	14	V
OFF threshold voltage	Voff		8	9	10	V
Hysteresis width	Vhysvcc		3.0	4.0	5.0	V

All devices (VCCPin)

Item	Symbol	Condition	MIN	TYP	MAX	Unit
Start-up current	Istart	Vcc=Von-0.1V	-	-	80	μA
Operating current	Icc		-	1.5	3.0	mA
Dynamic operating current	Iop	CL=1.0nF	-	2.0	4.0	mA
Standby current	Istb	Vfb=0V	-	30	60	μA

7. Characteristics curves

(Unless otherwise specified, $T_a=25^{\circ}\text{C}$ and $V_{cc}=12\text{V}$)

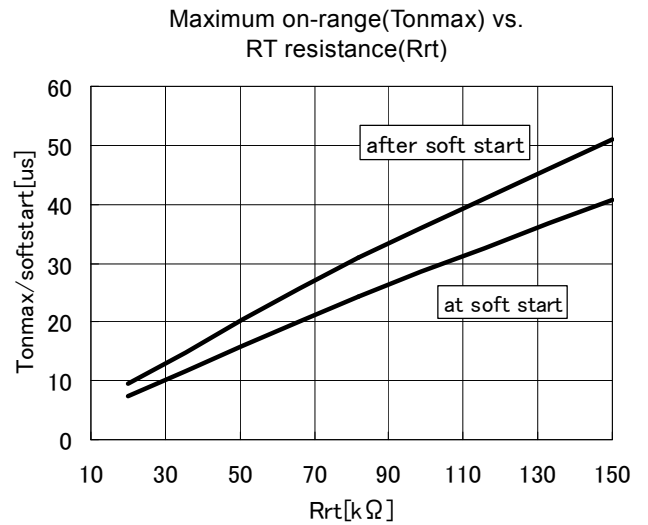
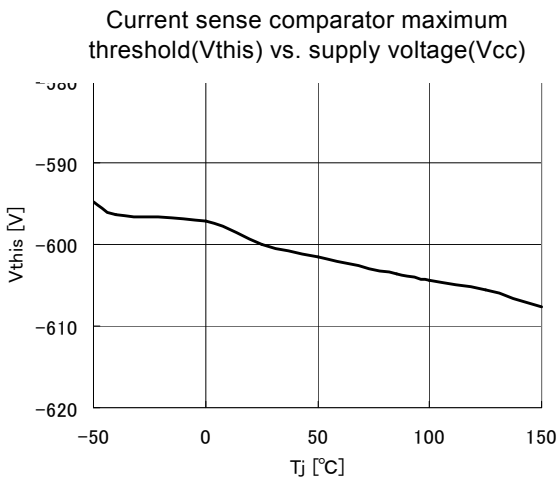
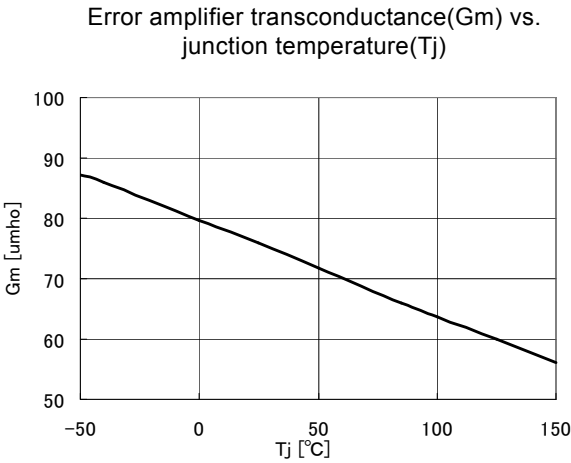
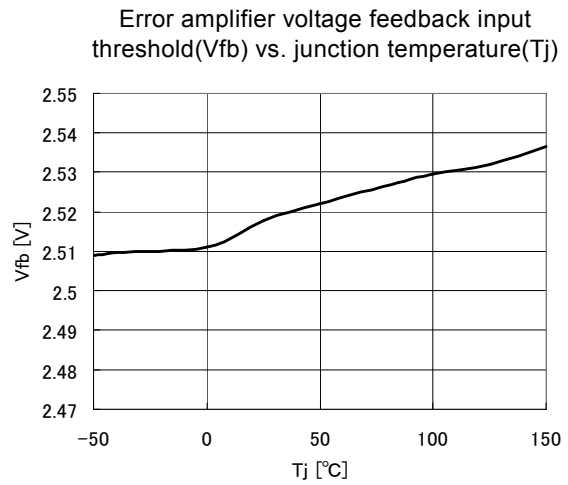
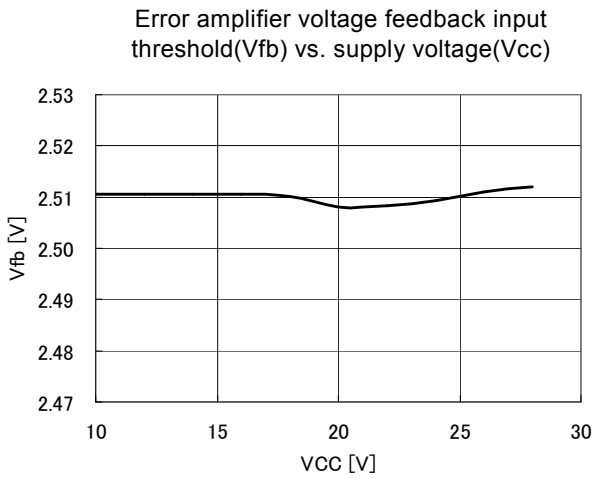

Maximum oscillating frequency(Fmax) vs. RT resistance(Rrt)

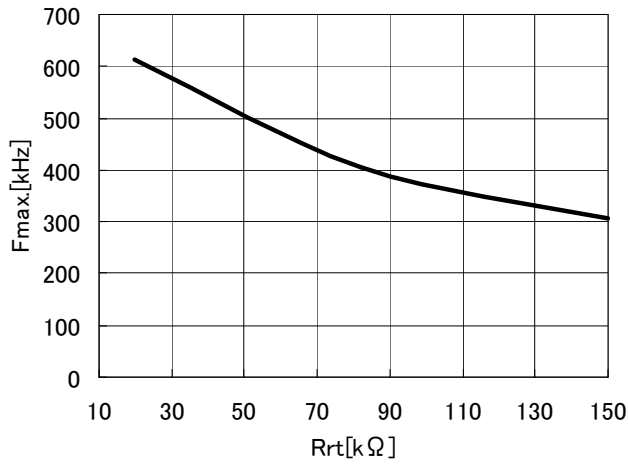

Zero current detection delay(Tzcd) vs. RT resistance(Rrt)

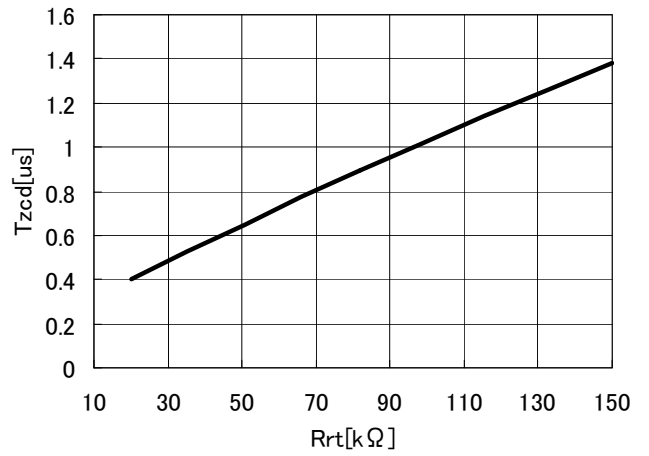

Standby current(Istb) vs. supply voltage(Vcc)

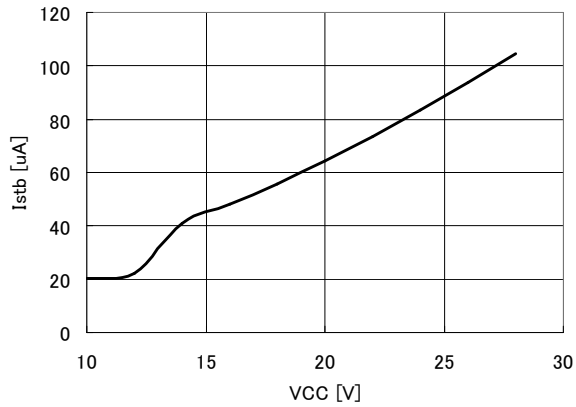

8. Outline of circuit operation

This IC is a power-factor correction converter utilizing a boosting chopper, operating in critical mode. Hereinafter is outline of the operation consisting of switching operation and power-factor correction operation using the circuit diagram shown in Fig. 1.

(1) Switching operation

This IC performs the switching operation in the critical mode applying self-oscillation without using an oscillator. Fig. 2 shows the outline of waveforms of the switching operation in steady state. The operation is as follows.

- t1. Q1 turns on, the current through inductor (L1) rises from zero. At the timing of Q1 on, V_{ramp} ; output of ramp generator starts to rise.
- t2. V_{ramp} and V_{comp} ; output of the error amplifier are compared by the PWM comparator, and when $V_{ramp} > V_{comp}$, Q1 turns off and the output of the ramp generator drops. When Q1 turns off, the voltage across L1 inverts and the current through L1 decreases while the current is supplied to the output side through D1.
- t3. The current through L1 is detected by IS terminal, and when the current becomes zero, the output of the current detection comparator becomes High to turn on Q1 after delay given by the delay circuit, thus moving to the next switching cycle (t1).

By repeating the operations of t1 ~ t3, the switching in critical mode is continued.

With the power-factor correction circuit in the critical mode, the switching frequency is always changing due to instantaneous values of the AC input voltage. The switching frequency also changes when the input voltage or load changes.

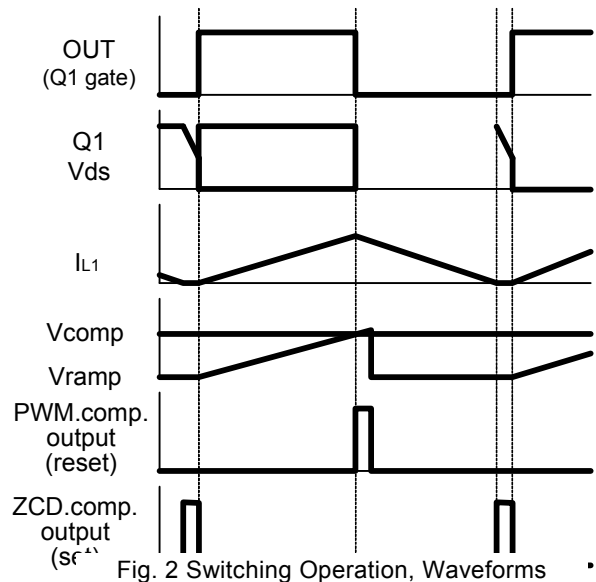

Fig. 2 Switching Operation, Waveforms

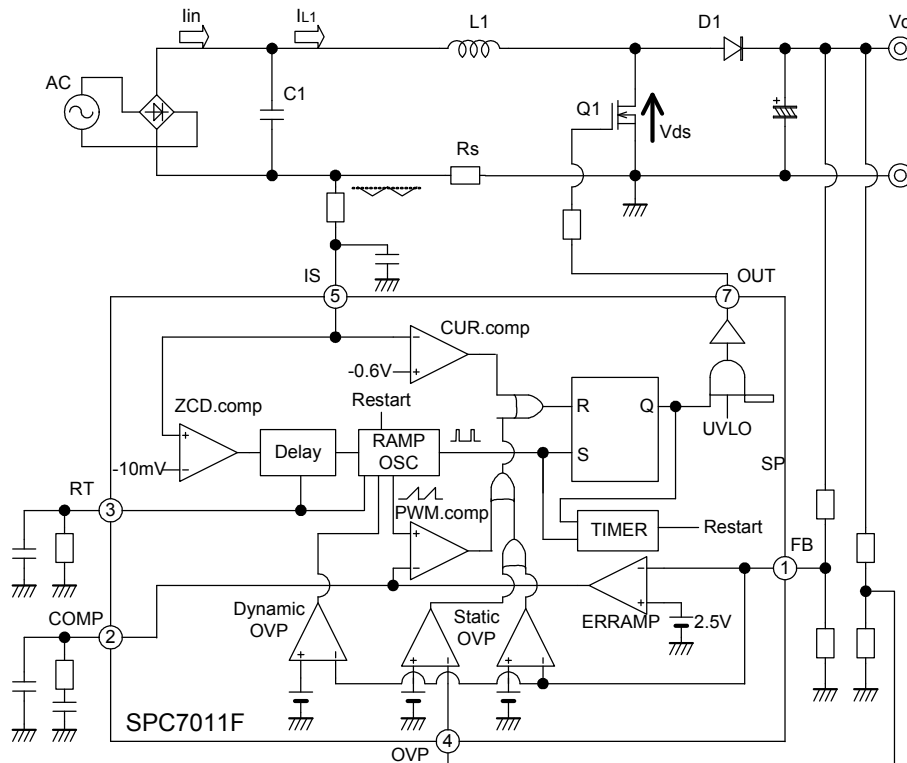

Fig.1 Block diagram of operating circuit

(2) Power-factor correction operation

As explained in the switching operation, the current flowing through the inductor repeats in triangular waveforms. The mean value ($I_{L1}(\text{mean})$) of the triangular wave current becomes 1/2 of the peak value ($I_{L1}(\text{peak})$). (Fig. 3)

By controlling to make outline linking the peak of the inductor current to sine wave and removing switching ripple current, the smoothed current flowing from the AC input power source has sine wave shape.

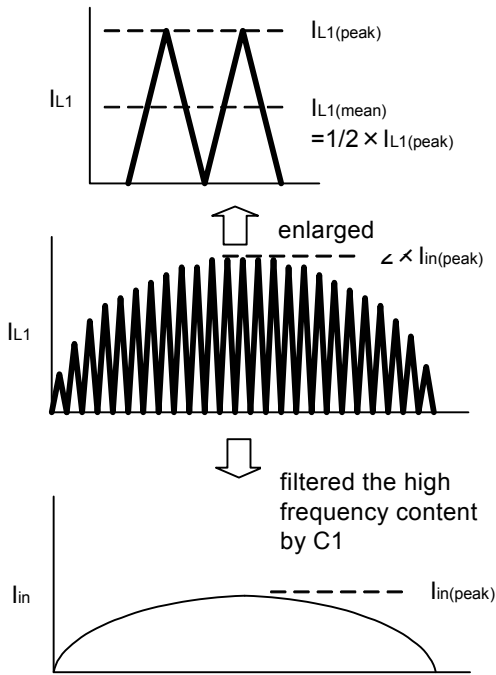

Fig.3 Outline of inductor and AC input current

FA5590/FA5591 uses fixed on time control shown in Fig. 4.

This control determines the on time of the output of IC (gate drive signal for Power Mos) with combination of the error amplifier output and saw tooth wave. While the load is constant, the output of the error amplifier is constant, and on time also stays constant.

Since an inclination of inductor current depends on input voltage (an inclination of inductor current is proportional to input voltage) and on time is constant, the outline linking the peak of the inductor current becomes same AC waveform as the input voltage, which enables power-factor correction operation.

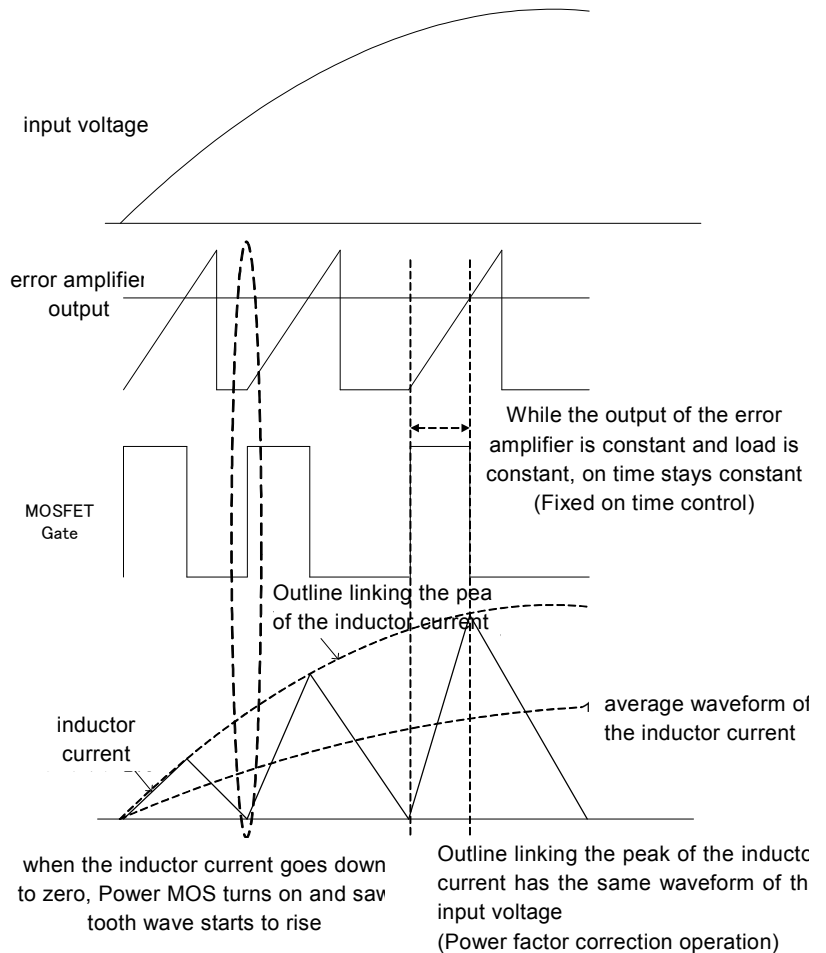

Fig.4 Fixed on time control

9. Description of each circuit block

(1) Error amplifier

The error amplifier is to make the output voltage constant with feedback control. For this IC, a transconductance type is used for the error amplifier.

The non-inverting input terminal is connected to internal reference voltage of 2.5V (typ.).

The inverting input terminal is fed with output voltage of the power-factor correction converter, and normally use divided voltage with resistors. To the inverting input, internal constant current source of 1.8μA is connected for FB open detection function.

The output of the error amplifier (COMP) is connected to the PWM comparator and controls the on time of the OUT output.

The output voltage of PFC contains much of ripple of frequency 2 times AC power line (50 or 60Hz). When this ripple component becomes largely appears in the output of the error amplifier, the power-factor correction converter does not stably operate. In order to obtain the stable operation, connect capacitors and a resistor at Pin No. 2 (COMP) as shown in Fig.5.

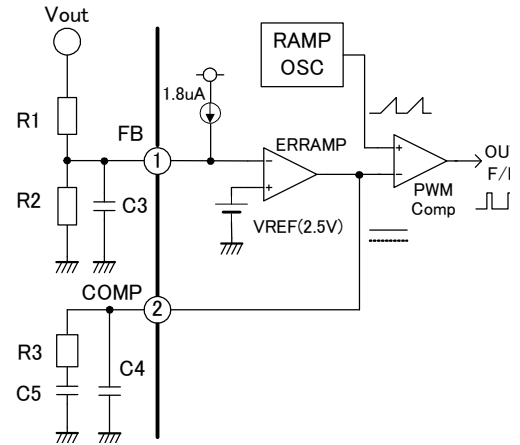

Fig.5 Error amplifier circuit

(2) Soft start circuit

FA5695 is equipped with soft start function to suppress rushing startup and overshoot of output voltage when starting.

The soft start circuit works after UVLO and standby is released and before the soft start cancellation voltage is exceeded. In the meantime, the soft start function restricts the startup speed of the output voltage by limiting the maximum on time to about 80% when the FB terminal voltage is lower than the reference voltage. (Fig. 6) The on time limited by the soft start is cancelled when the FB terminal voltage becomes higher than the soft start cancellation voltage.

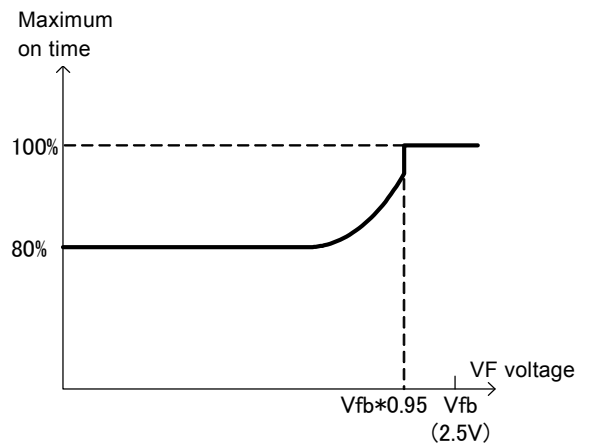

Fig.6 maximum on time at soft start

(3) Overvoltage protection circuit (OVP)

This circuit is to limit the voltage when the output voltage of the power-factor correction converter exceeds the set value.

When this IC starts up or load changes sharply, the output voltage of the converter may exceed the set value. In such a case, this protection circuit works to control the output voltage.

FA5695 has 2 of OVP function as shown below.

It controls the ON width linearly when the output exceeds the reference voltage.

Dynamic OVP - - - Built-in FB pin

It stops the output pulse when the output exceeds 1.08 times of reference voltage.

Static OVP - - - Built-in FB pin and OVP pin

The operation of FB pin which has two functions above is described below.

FB pin voltage is usually 2.5V as same as the reference voltage. When the startup or a sudden change of load, FB pin voltage rises and will exceed 2.5V. In this case, a function which limits ON width depending on FB pin voltage becomes active. (Dynamic OVP) If FB pin voltage rises more and exceeds a reference voltage of comparator ($V_{fb} * 1.08$), another function becomes active and stops the output pulse during exceeding the reference. (Fig.7)

When FB pin voltage decreases to 1.040 times of reference voltage or lower, IC outputs pulses again.

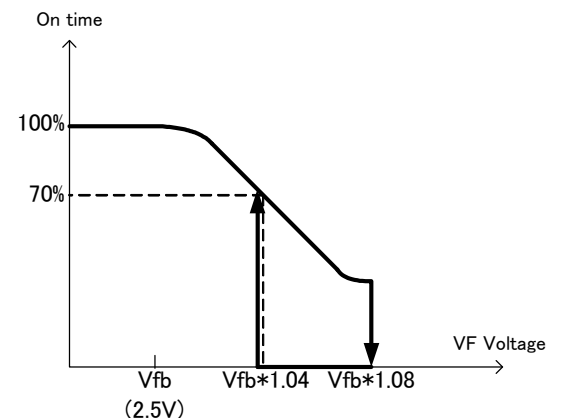

Fig.7 ON time at overvoltage

(4)FB short-circuit/open detection circuit

(Standby circuit)

In the PFC circuit of booster type, if feedback voltage is not properly provided to the FB terminal due to short-circuit or open-circuit around R1, R2, the error amplifier cannot control the constant voltage and the output voltage abnormally rises. In such a case, the overvoltage protection circuit also cannot operate because the detection of the output voltage is abnormal.

To avoid such situation, this IC is equipped with FB short-circuit detection circuit.

This circuit is composed of the reference voltage of 0.3V (typ.) and comparator (SP), and when the input voltage of the FB terminal becomes 0.3V or lower due to such trouble as short-circuit of R2 or opening of R1, the output of the comparator (SP) inverts to stop the output of the IC and the IC stops operation resulting in standby state.

Once the voltage of the FB terminal decreases to almost zero and the output of the IC stops, and then when the voltage of the FB terminal returns to 0.3V or higher, the IC resumes from the standby state and the OUT pulse restarts.

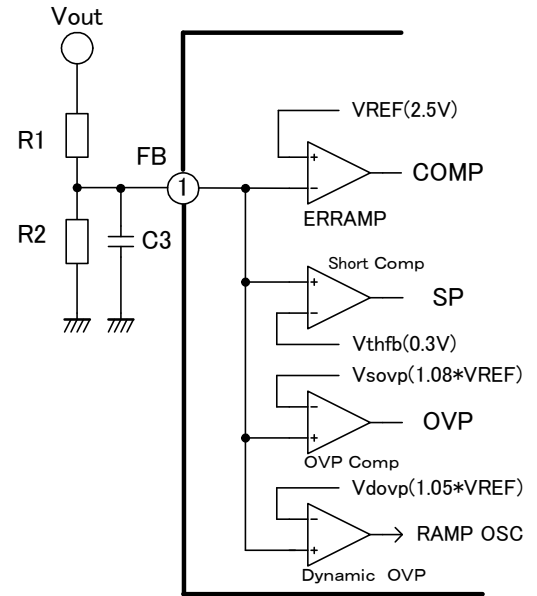

Fig.8 FB pin circuit

(5) Ramp oscillating circuit

The ramp oscillating circuit receives signal from the zero current detection circuit or restart circuit, and outputs the set signal of F/F for OUT output and saw tooth wave signal for deciding the duty of the PWM comparator.

(5-1) Maximum frequency limiting

The switching frequency of PFC in the critical mode has characteristic to rise at light load.

FA55901/91 has the maximum frequency limiting function to improve the efficiency at light load and limits the switching frequency to Fmax (Hz). (Fig. 10)

The maximum frequency Fmax depends on the resistance connected between the RT terminal and GND.

When the switching frequency is lower than Fmax, the zero level of the inductor current is detected and MOSFET is turned on after the zero current detection delay Tzcd to adjust turning on take place at the bottom of Vds wave, as shown in Fig. 11.

In case of light load where the switching frequency is limited to Fmax, the zero level of the inductor current is detected and no turn-on occurs after the zero current detection delay, but turn-on occurs at the cycle of 1/Fmax, as shown in Fig. 12.

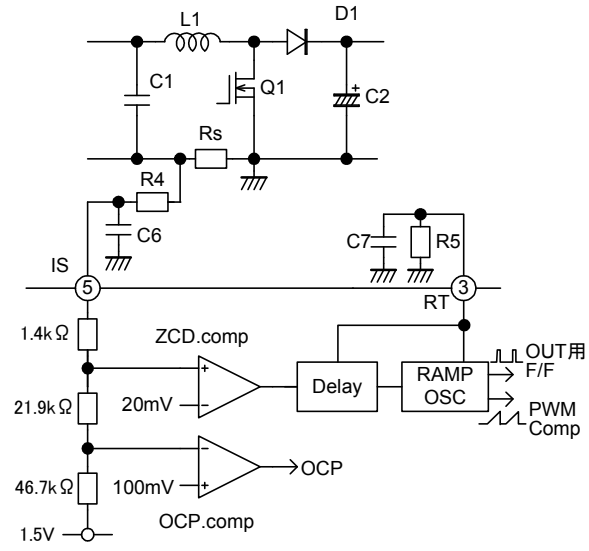

Fig.9 Current detection circuit

(6) Current detection circuit

The current detection circuit is composed of zero current detection and overcurrent detection. (Fig. 9)

(6-1) Zero current detection circuit

This IC performs the switching operation by self-oscillation in critical mode instead of the oscillator with the fixed frequency. The zero current detection circuit ZCD. Comp detects that the inductor current becomes zero to perform the critical mode operation.

With the zero current detection, the voltage across the current detection resistor Rs connected to the GND line is fed to the IS terminal, and it is compared by the zero current detection comparator, and when it becomes -4mV or more, the inductor current is regarded as zero level.

When the zero level is detected, the delay Tzcd is generated by the zero cross delay detection circuit, and then set the F/F for OUT to make MOSFET turn on.

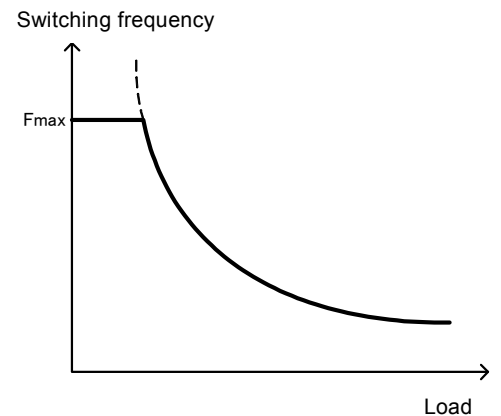

Fig.10 maximum frequency limiting

(6-2) Overcurrent detection protective circuit

The overcurrent detection protective circuit detects the inductor current and protects MOSFET by turning off the OUT output when it becomes higher than a set current level. With the overcurrent detection, the voltage across the current detection resistance R_s connected to the GND is fed to the IS terminal, and when the IS terminal voltage compared by the overcurrent detection comparator becomes lower than $-0.6V$, it is regarded as overcurrent state.

When the overcurrent is detected, the F/F for OUT output is reset to make MOSFET turn off.

(7) Zero cross delay time setting circuit

V_{ds} between the drain and the sources of the MOSFET starts oscillating through resonance of L_1 and the parasitic capacitor component on the circuit just before the MOSFET turns on.

When the proper value of R_t , the turn on timing of MOSFET can be adjusted at the bottom of the voltage oscillation. This makes it possible to minimize the switching loss and the surge current generated at the turn-on. (Fig. 13)

When the R_t is smaller, the turn-on timing becomes earlier, and vice versa. (Fig. 14)

Since the optimum value of this R_t changes depending on the circuit and input/output conditions, tuning up is required so as to achieve an optimum state while evaluating the operation with actual circuit.

(8) Restart timer

This IC utilizes self oscillation instead of the oscillator with fixed frequency, and in the steady operation, it turns on MOSFET with a signal from the zero current detector.

But in start up or light load condition, a trigger signal is required for starting up or stable operation.

This IC is provided with a restart timer, and when the output of IC continues turn off for $20\mu s$ or more, the trigger signal is automatically generated.

This signal can realize stable operation even when starting up or the load is light.

(9) Under Voltage Lock out (UVLO)

UVLO is equipped to prevent circuit malfunction when supply voltage drops.

When the supply voltage rises from zero, the operation starts at 13V (typ.).

When the supply voltage decreases after the operation starts, IC stops the operation at 9V (typ.).

When UVLO is on and IC stops operation the OUT terminal becomes LOW and cuts off the output. The current consumption of the IC decreases to 80uA or less.

(10) Output circuit portion

The output portion is of push-pull circuit and can directly drive the MOSFET. The peak current of the output portion is 1.0A maximum for sink and 1.0A maximum for source.

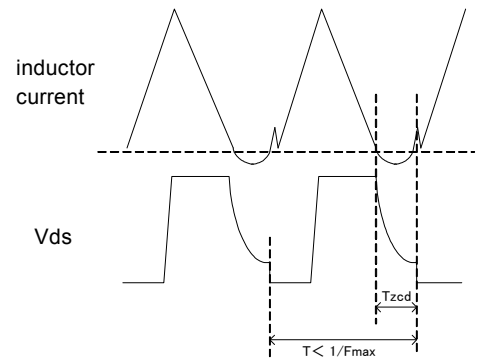

Fig.11 when the switching frequency is lower than the maximum frequency F_{max}

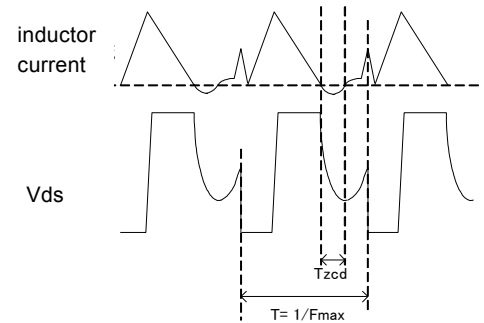

Fig.12 when the switching frequency is limited to the maximum frequency F_{max}

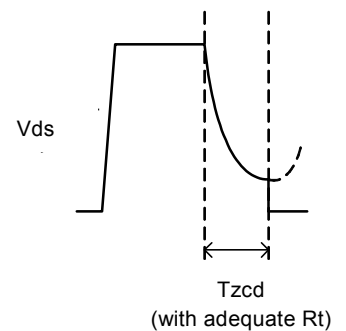

Fig.13 V_{ds} waveform at turn on (with adequate R_t)

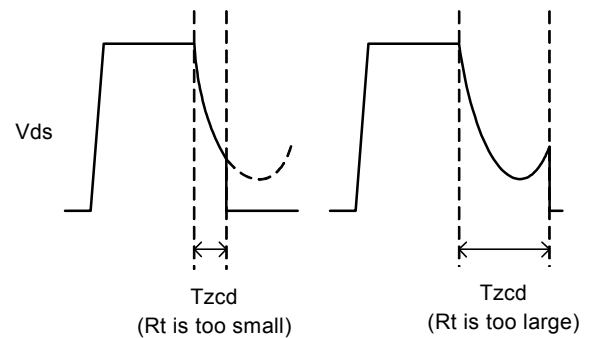

Fig.14 V_{ds} waveform at turn on (with inadequate R_t)

10. Description of use for each pin

(1) Terminal No. 1 (FB terminal)

Functions

- (i) Input of feedback signal of output voltage setting
- (ii) Detect short-circuit of FB terminal
- (iii) Detect output overvoltage

Application

- (i) Feedback signal input

- Wiring

Connect the node between voltage dividing resistors for setting output voltage.

- Operation

The output voltage V_{out} of PFC is controlled so that FB voltage matches the internal reference voltage (2.5V).

$$V_{out} = \frac{V_{REF}}{R_2} \times R_1 + V_{REF}$$

V_{REF} : Reference voltage = 2.5V (typ.)

To prevent malfunction due to noise, capacitor C3 of 100pF~3300pF should be connected between the FB terminal and GND.

- (ii) FB terminal short-circuit detection

- Wiring

Same as for the (i) Feedback signal input

- Operation

When the input voltage of the FB terminal becomes 0.3V or lower due to short-circuit of R2, the output of the comparator (SP) inverts to stop the output of the IC.

- (iii) Output overvoltage detection

- Wiring

Same as for the (i) Feedback signal input

- Operation

Normally the voltage of the FB terminal is 2.5V almost same as the reference voltage of the error amplifier. When the output voltage rises for some reason and the voltage of the FB terminal reaches the comparator reference voltage (1.08* V_{REF}), the output of the comparator (OVP) inverts to stop the OUT pulse. If the output voltage returns to the normal value, the OUT pulse resumes.

(2) Terminal No. 2 (COMP terminal)

Function

- (i) Phase compensation of internal ERRAMP output

Application

- (i) Phase compensation of internal ERRAMP output

- Wiring

Connect C, R between COMP terminal and GND as shown in Fig. 16.

- Operation

Connecting C, R to the COMP terminal suppress ripple component at 2 times the frequency of the AC line that appears in the FB output.

(Reference)

Example of application circuit : C4=0.15uF
 C5=0.15uF
 R3=68kΩ

The above is a reference example, and it should be decided by sufficiently verifying with actual application circuit.

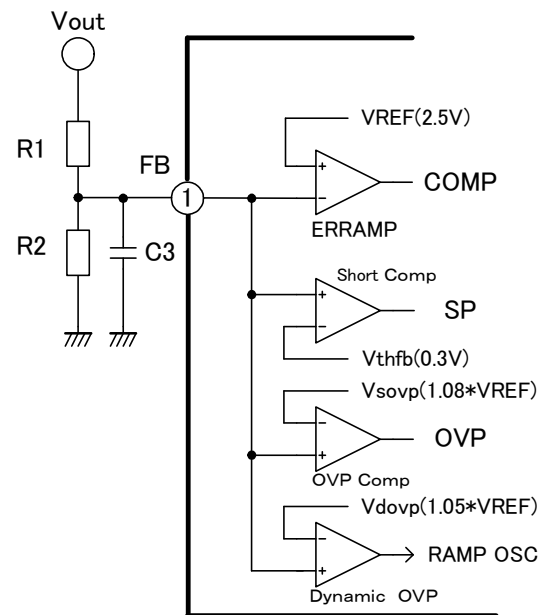

Fig.15 FB pin circuit

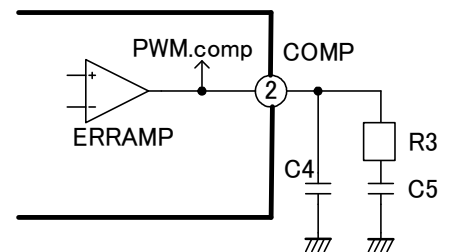

Fig.16 COMP pin circuit

(3) Terminal No. 3 (RT terminal)

Functions

- (i) Set maximum on time
- (ii) Set maximum oscillation frequency
- (iii) Set delay time for zero current detection

Application

- (i) Set maximum on time

On time T_{on} in each switching cycle with input and output conditions is theoretically expressed by the following formula.

$$T_{on} = \frac{2 \times L_p \times P_o}{V_{ac}^2 \times \eta}$$

Input Voltage (V_{rms}): V_{ac}

Inductor (H): L_p

Maximum Output Power (W): P_o

Efficiency: η

The maximum on time T_{onmax} must be set equal to or more than the on time at minimum input voltage V_{ac} (min) at which the on time is maximum. In soft start, the maximum on time is limited to 80%, and therefore, the maximum on time should be set as shown by the following formula.

$$T_{onmax} > \frac{2 \times L_p \times P_o}{V_{ac(min)}^2 \times \eta \times 0.8}$$

- (ii) Set maximum oscillation frequency

To improve the efficiency at light load, FA5695 limits switching frequency at light load to F_{max} (Hz). The maximum frequency F_{max} depends on the resistance connected between RT terminal and GND.

- Wiring

Connect R5 between RT and GND as shown in Fig. 17.

For the resistance dependency of the maximum on time and maximum oscillation frequency, see Chapter 7. Characteristic Curve.

The current sourced from the RT terminal changes depending on the resistance connected. When R5 is relatively large, for example, 82kΩ, the current is about 10uA. When the current is relatively small, it is recommended to connect a capacitor of about 0.01uF in parallel to the resistor to stabilize the RT voltage, as shown in the figure.

- (iii) Set delay time for zero current detection

Select a resistance value so as to set such delay time that MOSFET will turn on at the bottom of the vds waveform. (V_{ds} is almost 0V)

However, very smaller resistance makes maximum ON width T_{onmax} narrower and maximum output power fewer. Avoid choosing the resistance which gives narrower ON width than the result of above equation.

If the resistance gives much longer delay time, we recommend an adjustment of the delay time by the resonant capacitor.

(4) Terminal No. 4 (OVP terminal)

Function

- (i) Set detection level of OVP

It sets a voltage which detects an over voltage of output and which stop switching operation.

For avoiding malfunction by noise, the recommended resistance of the detection circuit is 10Mohm or smaller.

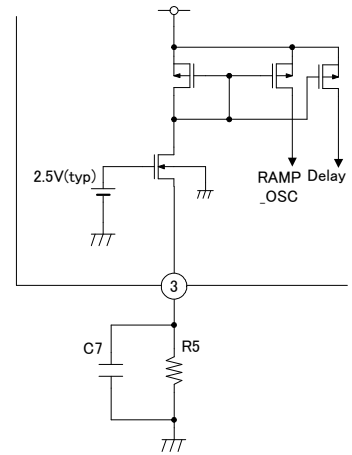

Fig.17 RT pin circuit

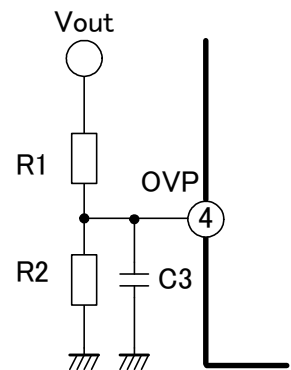

Fig.18 OVP pin circuit

(5) Terminal No. 5 (IS terminal)

Function

- (i) Detect zero current through the inductor
- (ii) Detect overcurrent and turn off OUT output

Application

- (i) Detect the current value through the inductor

The maximum threshold voltage V_{thIS} of the IS terminal is -0.58V (max). The current detection resistance R_s is set so that necessary current can be supplied for this V_{thIS} .

With maximum output P_o (W) and minimum input voltage V_{ac} (min), the maximum value of peak current (I_{LP} (max)) through the inductor can be approximately expressed by the following formula.

$$I_{LP(max)} = \frac{2 \times \sqrt{2} \times P_o}{\eta \times V_{ac(min)}}$$

Therefore, the value of R_S (Ω) is determined as follows.

$$R_s < \frac{-V_{thIS}}{I_{LP(max)}} = \frac{0.58}{I_{LP(max)}}$$

- Wiring

Connect the current detection resistor R_s between the source terminal (GND) of MOSFET and the minus lead of the input capacitor (C_1). The voltage across R_s is fed to the IC as the current/voltage conversion signal.

- Operation

- (i) The internal reference voltage and the internally divided voltage of the IS terminal are inputted to the ZCD comparator, and when the IS terminal voltage becomes larger than -10mV, the comparator output inverts and turns on the OUT output.
- (ii) When the IS terminal voltage becomes smaller than -0.6V, the comparator output signal inverts and turns off the OUT output.

- Additional explanation

When MOSFET turns on, the gate driving current of MOSFET and surge current due to discharging the parasitic capacitors run to the current detection resistance R_s . Large surge current may cause malfunction following disturbed input current waveform. Depending on the amperage of the surge current or timing, whisker-like pulse may be mixed in the turn-on portion of the OUT pulse of the IC. Normally, therefore, a CR filter is connected as shown in Fig.20. The cutoff frequency of this CR filter must be set sufficiently higher than the switching frequency so that it will not affect the normal operation.

It is recommended to set this cutoff frequency to about 1~2MHz.

$$\frac{1}{2 \times \pi \times C_6 \times R_4} \doteq 1 \sim 2 [\text{MHz}]$$

Since the threshold level is made through resistance dividing voltage as shown in Fig.19, the input resistor R_4 is recommended to be not higher than 47 Ω .

The voltage rating of the IS terminal is -5V. In case of an ordinary boosting circuit, rush current to charge the output smoothing capacitor C_2 runs at the moment the ac input voltage is connected. This current may become far larger in comparison with the input current during normal operation.

As a result, far larger voltage may also be applied to the IS terminal than the ordinary case.

In order to avoid damage, protective circuit must be taken in design so that voltage higher than -5V, absolute maximum rating, will not be applied to the IS terminal even when such ac input voltage is connected. If voltage higher than the rating is predicted to be applied to the IS terminal, use rush preventive circuit suppress rushing current or place Zener diode shown in Fig. 20 and Fig. 21.

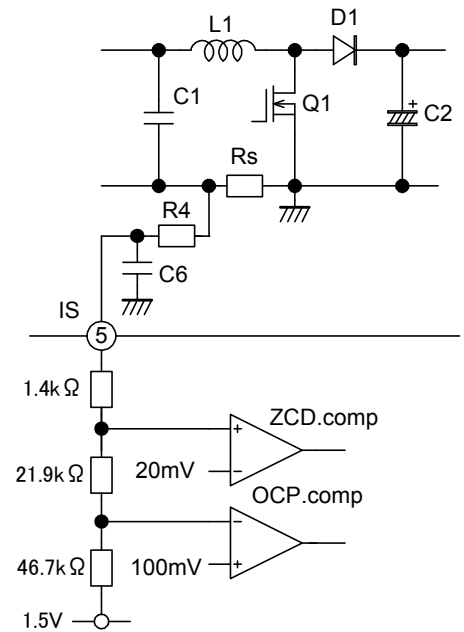

Fig.19 IS pin circuit

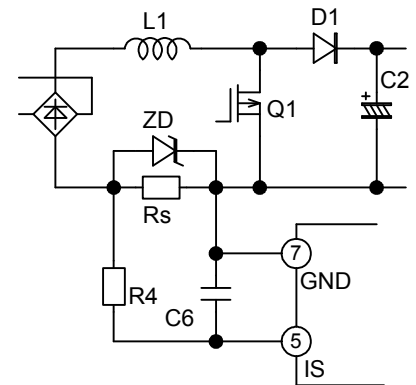

Fig.20 IS pin protection circuit (1)

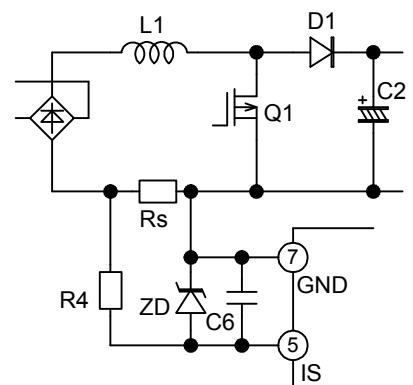

Fig.21 IS pin protection circuit (2)

(6) Terminal No. 6 (GND terminal)

Function

This voltage of GND terminal is the reference for each portion of whole circuits.

(7) Terminal No. 7 (OUT terminal)

Function

This drives MOSFET.

Application

- Wiring

Connect it to the gate terminal of MOSFET through resistance.

- Operation

During the period when turn on MOSFET, the output state is high, and the output voltage is almost VCC.

During the period when turn off MOSFET, the output state is low, and the output voltage is almost 0V.

- Additional explanation

The gate resistor is connected to limit the current of the OUT terminal and prevent oscillation of the gate terminal voltage. The rating of the output current is 1.0A for source and 1A for sink.

Using the connections shown in Fig. 23 and Fig. 24, it is possible to independently set the gate driving current of turning on and off MOSFET.

(8) Terminal No. 8 (VCC terminal)

Function

(i) Supply the power of IC.

Application

- Wiring

Connect the start up resistor R7 between VCC terminal and Voltage line after rectifying from AC line, which supplies power before IC starts switching operation.

In general application, the power is provided from the auxiliary winding of the transformer through D2 during operation.

In some application, DC power supply can be connected.

- Operation

In the application with out DC power supply to feed VCC terminal, the current through start up resistor R7 charges the smoothing capacitors C5 and C9, and when VCC voltage rises to the on threshold voltage of UVLO, the IC starts operating. Before starting operation, it is necessary to supply current higher than 80uA (max), the startup current of the IC. During steady operation, the VCC is supplied from the auxiliary winding of the inductor. (Fig. 25)

When the supply voltage rises from zero, the operation starts at 13V (typ.).

If the supply voltage decreases after the operation starts, the operation stops at 9V (typ.) by UVLO. After IC stops operation due to UVLO, the OUT terminal is Low state to cut off the output.

Additional explanation

UVLO is preventive function to keep the circuit from malfunction when the supply voltage decreases.

With the start up resistor R7, it is necessary to supply current of 80μA or higher, the startup current, until start operating, and the following formula must be satisfied.

$$R7 < \frac{\sqrt{2} \times Vac(\min) - Von(\max)}{80 \times 10^{-6}}$$

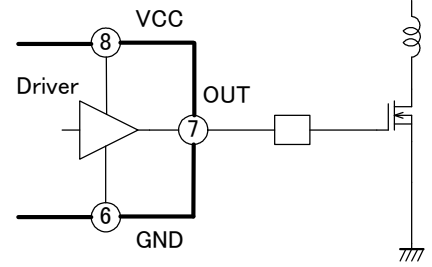

Fig.22 OUT pin circuit(1)

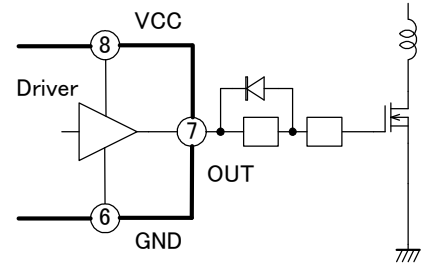

Fig.23 OUT pin circuit(2)

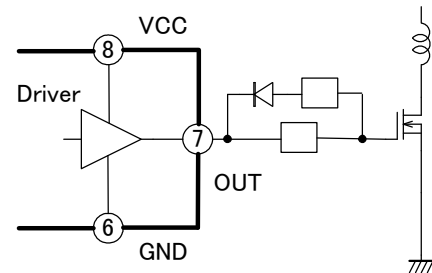

Fig.24 Out pin circuit(3)

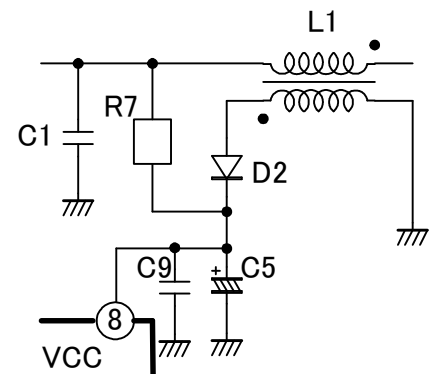

Fig.25 VCC pin circuit(1)

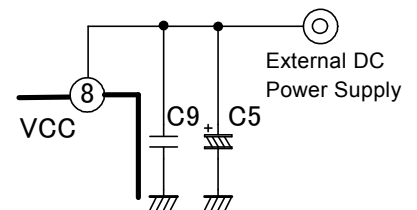

Fig.26 VCC pin circuit(2)

Von(max): Low voltage ON threshold voltage of UVLO 14V(max.)

The value of R7 expressed with the formula is, however, at least necessary and minimum condition to start the IC, and actually it should be decided considering the starting up time required for each application circuit.

This starting up time must be examined by measuring in actual circuit operation.

During the steady operation, Vcc is supplied from the auxiliary winding of the transformer. But there is some time delay until the auxiliary winding voltage sufficiently rises after the IC starts switching operation. To prevent Vcc from decreasing to the off threshold voltage of UVLO, it is necessary to decide the capacitance of the C5 connected to Vcc. Since this time delay differs depending on the circuit, it should be decided after checking with actual circuit

It is also recommended to place the ceramic capacitor C9 (about 0.1uF) to remove switching noise.

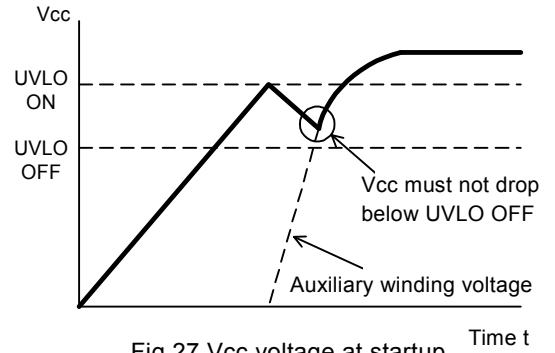

Fig.27 Vcc voltage at startup

(9) Minus voltage of each terminal

In some cases, the voltage oscillation of Vds just before MOSFET turns on is applied to the OUT terminal through parasitic capacitors, etc. and minus voltage may be added to the OUT terminal. If this minus voltage is large, the parasitic element inside the IC is activated, and the IC may malfunction.

If this minus voltage is expected to exceed -0.3V, Schottky barrier diode should be connected between the OUT terminal and GND. With the forward voltage of the Schottky barrier diode, the minus voltage can be clamped.

For other terminals as well, care should be taken so that minus voltage will not be applied in the same way.

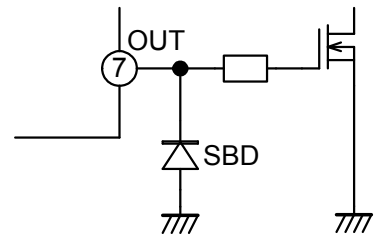

Fig.28 Protection circuit of OUT pin against the negative voltage

12 Advice for design

(1) advice in pattern designing

Main power parts such as MOSFET, inductor, and diode in the main switching circuit are operating with large voltage and current. For this reason, if the IC or wires of input signals are located close to these main power parts, malfunction may occur affected by noise generated there.

Special care should be taken to the following cases. (Bad examples)

- IC is placed under the main circuit parts such as inductor or just on the back side of the main circuit parts in case of a double-sided board. (Fig. 29)
- IC is placed just beside the inductor, MOSFET or diode. (Fig. 30)
- Signal wires are placed under the inductor or near MOSFET or diode. (Fig. 31)

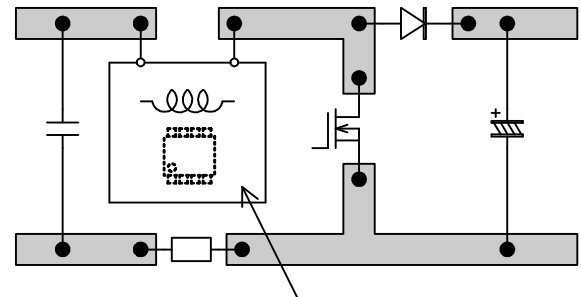

IC is placed under the inductor

Fig.29 Bad example (1)

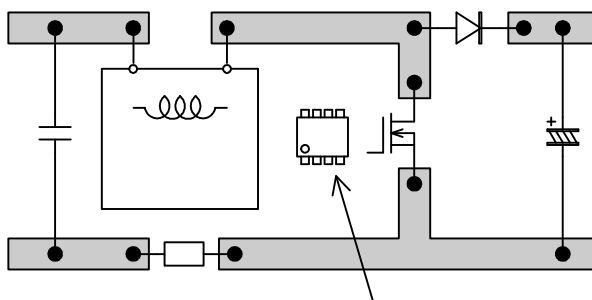

IC is placed just beside the inductor, MOSFET

Fig.30 Bad example (2)

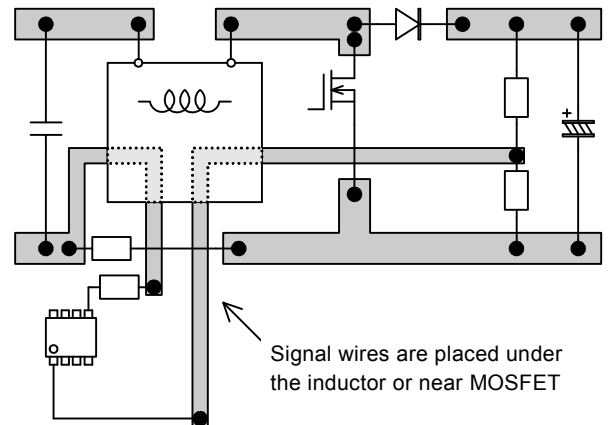

Signal wires are placed under the inductor or near MOSFET

Fig.31 Bad example (3)

(2) Example of GND wiring around IC

(Note)

This wiring example is to make users understand the idea of GND wiring. The occurrence conditions of noise and malfunction are different depending on each application circuit, and it is not to guarantee that all application circuit will normally operate even if you use this wiring example (Fig. 32).

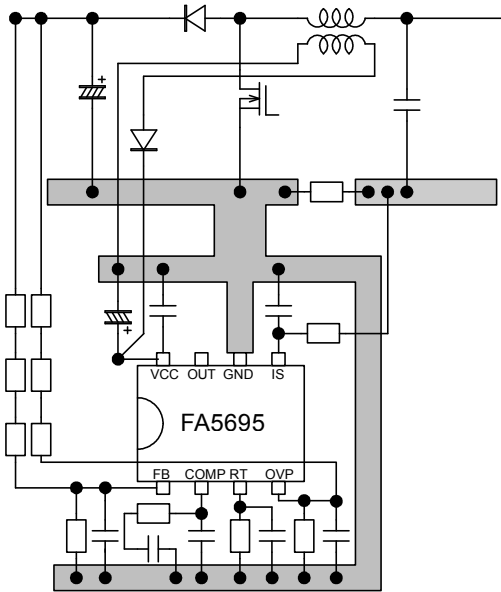

Fig.32 Good example of GND wiring around IC

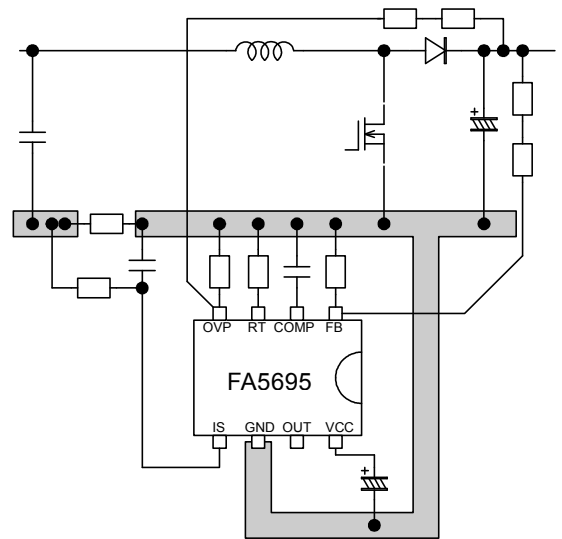

Fig.33 Bad example of GND wiring around IC

13 Example of application circuit

