



M24128 M24C64 M24C32

128 Kbit, 64 Kbit and 32 Kbit serial I²C bus EEPROM

Feature summary

- Two-Wire I²C serial interface
Supports 400kHz Protocol
- Single supply voltages (see [Table 1](#) for root part numbers):
 - 2.5 to 5.5V
 - 1.8 to 5.5V
 - 1.7 to 5.5V
- Write Control Input
- Byte and Page Write
- Random And Sequential Read modes
- Self-Timed programming cycle
- Automatic address incrementing
- Enhanced ESD/Latch-Up Protection
- More than 1 Million Write cycles
- More than 40-year data retention
- Packages
 - ECOPACK® (RoHS compliant)

Table 1. Product list

Reference	Root part number	Supply voltage
M24128	M24128-BW	2.5 to 5.5V
	M24128-BR	1.8 to 5.5V
M24C64	M24C64-W	2.5 to 5.5V
	M24C64-R	1.8 to 5.5V
	M24C64-F	1.7 to 5.5V
M24C32	M24C32-W	2.5 to 5.5V
	M24C32-R	1.8 to 5.5V
	M24C32-F	1.7 to 5.5V

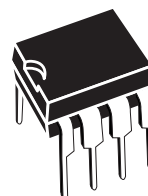

PDIP8 (BN)



SO8 (MN)
150 mil width



TSSOP8 (DW)
169 mil width



UFDFPN8 (MB)
2x3mm² (MLP)

Contents

1	Summary description	6
2	Signal description	8
	2.0.1 Serial Clock (SCL)	8
	2.0.2 Serial Data (SDA)	8
2.1	Chip Enable (E0, E1, E2)	8
2.2	Write Control (\overline{WC})	8
2.3	Supply voltage (V_{CC})	9
	2.3.1 Operating supply voltage V_{CC}	9
	2.3.2 Internal device reset	9
	2.3.3 Power-down	9
3	Memory organization	11
4	Device operation	12
4.1	Start condition	12
4.2	Stop condition	12
4.3	Acknowledge bit (ACK)	12
4.4	Data Input	12
4.5	Memory addressing	13
4.6	Write operations	15
4.7	Byte Write	15
4.8	Page Write	15
4.9	Minimizing system delays by polling on ACK	17
4.10	Read operations	19
4.11	Random Address Read	19
4.12	Current Address Read	19
4.13	Sequential Read	19
4.14	Acknowledge in Read mode	19
5	Initial delivery state	20
6	Maximum rating	20

7	DC and AC parameters	21
8	Package mechanical	27
9	Part numbering	31
10	Revision history	32

List of tables

Table 1.	Product list	1
Table 2.	Signal names	7
Table 3.	Device select code	10
Table 4.	Address most significant byte	10
Table 5.	Address least significant byte	10
Table 6.	Operating modes	13
Table 7.	Absolute maximum ratings	20
Table 8.	Operating conditions (M24128-BW, M24C64-W, M24C32-W)	21
Table 9.	Operating conditions (M24128-BR, M24C64-R, M24C32-R)	21
Table 10.	Operating conditions (M24C64-F, M24C32-F)	21
Table 11.	AC test measurement conditions	21
Table 12.	Input parameters	22
Table 13.	DC characteristics ($V_{CC} = 2.5V$ to $5.5V$, device grade 6)	22
Table 14.	DC characteristics ($V_{CC} = 2.5V$ to $5.5V$, device grade 3)	23
Table 15.	DC characteristics ($V_{CC} = 1.8V$ to $5.5V$)	23
Table 16.	DC characteristics ($V_{CC} = 1.7V$ to $5.5V$)	24
Table 17.	AC characteristics ($V_{CC} = 2.5V$ to $5.5V$, device grades 6 and 3)	25
Table 18.	AC characteristics ($V_{CC} = 1.8V$ to $5.5V$ or $V_{CC} = 1.7V$ to $5.5V$)	25
Table 19.	PDIP8 – 8 pin Plastic DIP, 0.25mm lead frame, package mechanical data	27
Table 20.	SO8 narrow – 8 lead Plastic Small Outline, 150 mils body width, package mechanical data	28
Table 21.	TSSOP8 – 8 lead Thin Shrink Small Outline, package mechanical data	29
Table 22.	UFDFPN8 (MLP8) – 8-lead Ultra thin Fine pitch Dual Flat Package No lead $2 \times 3mm$, package mechanical data	30
Table 23.	Ordering information scheme	31
Table 24.	Document revision history	32

List of figures

Figure 1.	Logic diagram	6
Figure 2.	DIP, SO, TSSOP and UDFPN connections	7
Figure 3.	Device select code	8
Figure 4.	Maximum RP value versus bus parasitic capacitance (C) for an I2C bus	9
Figure 5.	I ² C bus protocol	10
Figure 6.	Block diagram	11
Figure 7.	Write mode sequences with $\overline{WC} = 1$ (data write inhibited)	14
Figure 8.	Write mode sequences with $\overline{WC} = 0$ (data write enabled)	16
Figure 9.	Write cycle polling flowchart using ACK	17
Figure 10.	Read mode sequences	18
Figure 11.	AC test measurement I/O waveform	21
Figure 12.	AC waveforms	26
Figure 13.	PDIP8 – 8 pin Plastic DIP, 0.25mm lead frame, package outline	27
Figure 14.	SO8 narrow – 8 lead Plastic Small Outline, 150 mils body width, package outline	28
Figure 15.	TSSOP8 – 8 lead Thin Shrink Small Outline, package outline	29
Figure 16.	UDFPN8 (MLP8) – 8-lead Ultra thin Fine pitch Dual Flat Package No lead 2 × 3mm, package outline	30

1 Summary description

The M24C32, M24C64 and M24128 devices are I²C-compatible electrically erasable programmable memories (EEPROM). They are organized as 4096 × 8 bits, 8192 × 8 bits and 16384 × 8 bits, respectively.

In order to meet environmental requirements, ST offers these devices in ECOPACK® packages.

ECOPACK® packages are Lead-free and RoHS compliant. ECOPACK is an ST trademark. ECOPACK specifications are available at: www.st.com.

Figure 1. Logic diagram

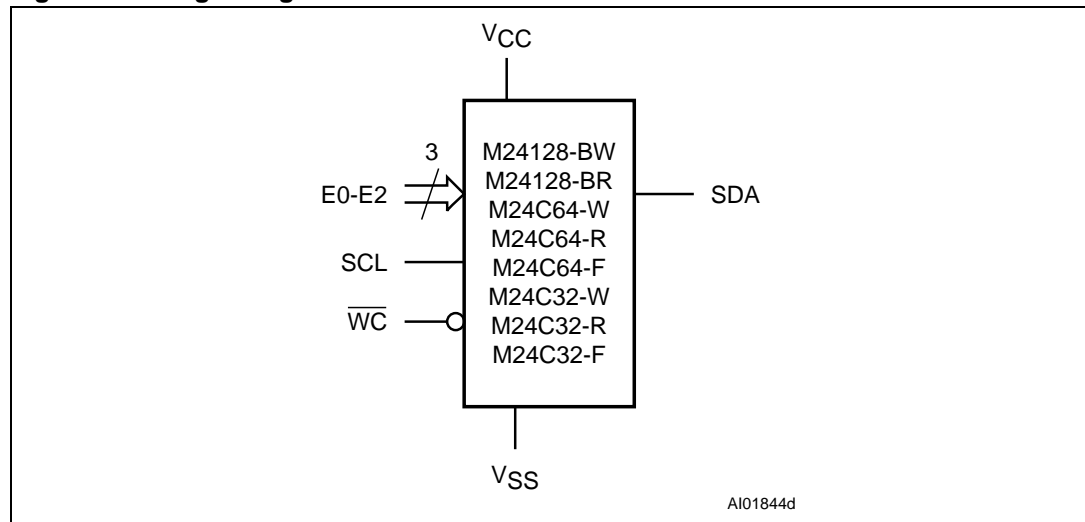

I²C uses a two-wire serial interface, comprising a bi-directional data line and a clock line. The devices carry a built-in 4-bit Device Type Identifier code (1010) in accordance with the I²C bus definition.

The device behaves as a slave in the I²C protocol, with all memory operations synchronized by the serial clock. Read and Write operations are initiated by a Start condition, generated by the bus master. The Start condition is followed by a Device Select Code and Read/Write bit (\overline{RW}) (as described in [Table 3](#)), terminated by an acknowledge bit.

When writing data to the memory, the device inserts an acknowledge bit during the 9th bit time, following the bus master's 8-bit transmission. When data is read by the bus master, the bus master acknowledges the receipt of the data byte in the same way. Data transfers are terminated by a Stop condition after an Ack for Write, and after a NoAck for Read.

Table 2. Signal names

E0, E1, E2	Chip Enable
SDA	Serial Data
SCL	Serial Clock
WC	Write Control
V _{CC}	Supply Voltage
V _{SS}	Ground

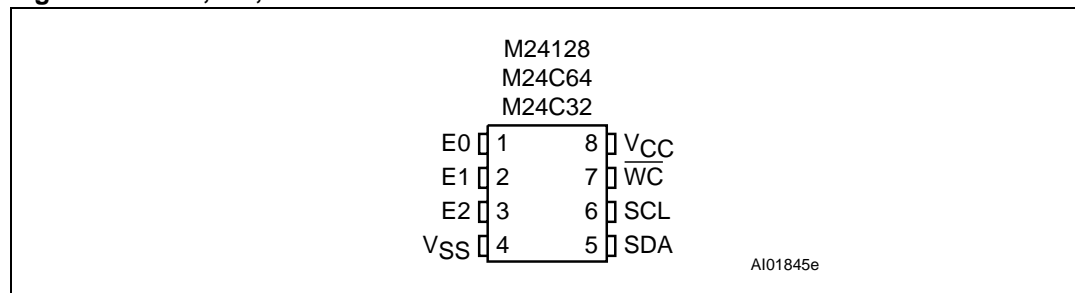
Figure 2. DIP, SO, TSSOP and UDFPN connections

1. See [Package mechanical](#) section for package dimensions, and how to identify pin-1.

2 Signal description

2.0.1 Serial Clock (SCL)

This input signal is used to strobe all data in and out of the device. In applications where this signal is used by slave devices to synchronize the bus to a slower clock, the bus master must have an open drain output, and a pull-up resistor must be connected from Serial Clock (SCL) to V_{CC} . (Figure 4 indicates how the value of the pull-up resistor can be calculated). In most applications, though, this method of synchronization is not employed, and so the pull-up resistor is not necessary, provided that the bus master has a push-pull (rather than open drain) output.

2.0.2 Serial Data (SDA)

This bi-directional signal is used to transfer data in or out of the device. It is an open drain output that may be wire-OR'ed with other open drain or open collector signals on the bus. A pull up resistor must be connected from Serial Data (SDA) to V_{CC} . (Figure 4 indicates how the value of the pull-up resistor can be calculated).

2.1 Chip Enable (E0, E1, E2)

These input signals are used to set the value that is to be looked for on the three least significant bits (b3, b2, b1) of the 7-bit Device Select Code. These inputs must be tied to V_{CC} or V_{SS} , to establish the Device Select Code as shown in Figure 3. When not connected (left floating), these inputs are read as Low (0,0,0).

Figure 3. Device select code

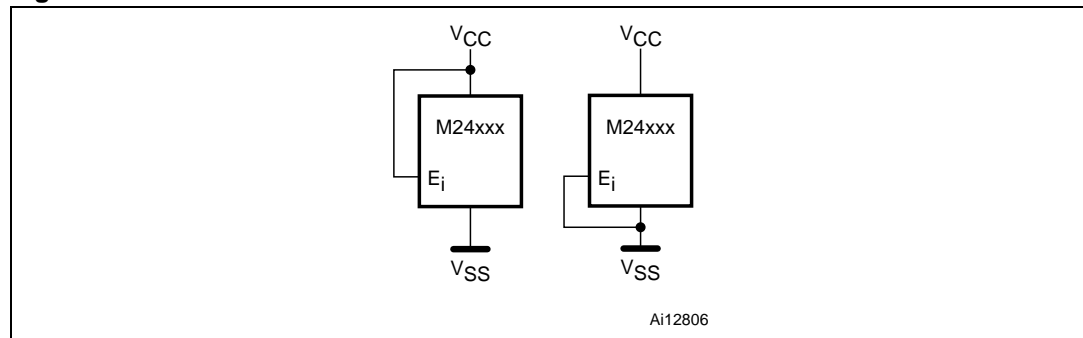

2.2 Write Control (\overline{WC})

This input signal is useful for protecting the entire contents of the memory from inadvertent write operations. Write operations are disabled to the entire memory array when Write Control (\overline{WC}) is driven High. When unconnected, the signal is internally read as V_{IL} , and Write operations are allowed.

When Write Control (\overline{WC}) is driven High, Device Select and Address bytes are acknowledged, Data bytes are not acknowledged.

2.3 Supply voltage (V_{CC})

2.3.1 Operating supply voltage V_{CC}

Prior to selecting the memory and issuing instructions to it, a valid and stable V_{CC} voltage within the specified [$V_{CC}(\min)$, $V_{CC}(\max)$] range must be applied (see [Table 9](#) and [Table 10](#)). In order to secure a stable DC supply voltage, it is recommended to decouple the V_{CC} line with a suitable capacitor (usually of the order of 10nF to 100nF) close to the V_{CC}/V_{SS} package pins.

This voltage must remain stable and valid until the end of the transmission of the instruction and, for a Write instruction, until the completion of the internal write cycle (t_W).

2.3.2 Internal device reset

In order to prevent inadvertent Write operations during Power-up, a Power On Reset (POR) circuit is included. At Power-up (continuous rise of V_{CC}), the device does not respond to any instruction until V_{CC} has reached the Power On Reset threshold voltage (this threshold is lower than the minimum V_{CC} operating voltage defined in [Table 9](#) and [Table 10](#)).

When V_{CC} has passed the POR threshold, the device is reset and is in Standby Power mode.

2.3.3 Power-down

At Power-down (continuous decrease of V_{CC}), as soon as V_{CC} drops from the normal operating voltage to below the Power On Reset threshold voltage, the device stops responding to any instruction sent to it.

During Power-down, the device must be deselected and in the Standby Power mode (that is there should be no internal Write cycle in progress).

Figure 4. Maximum R_P value versus bus parasitic capacitance (C) for an I²C bus

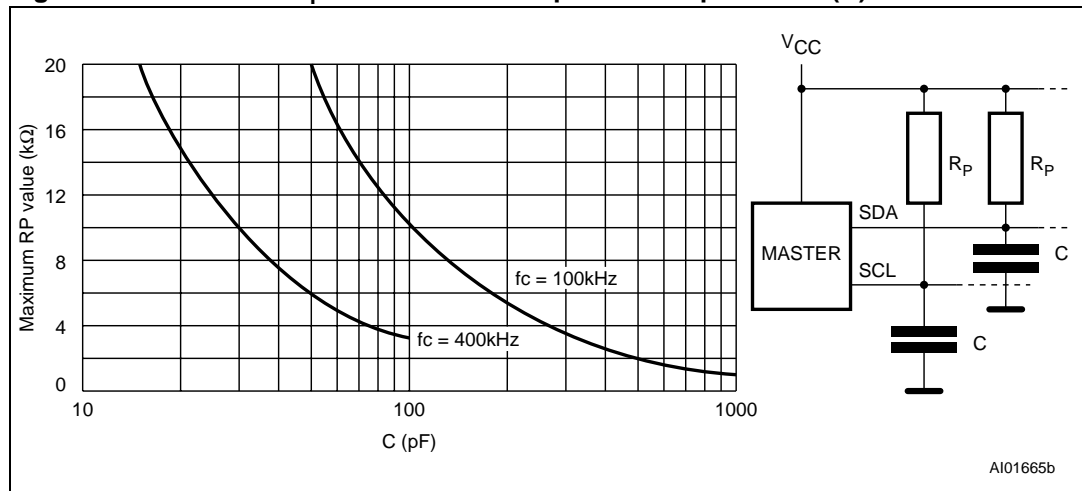

Figure 5. I²C bus protocol

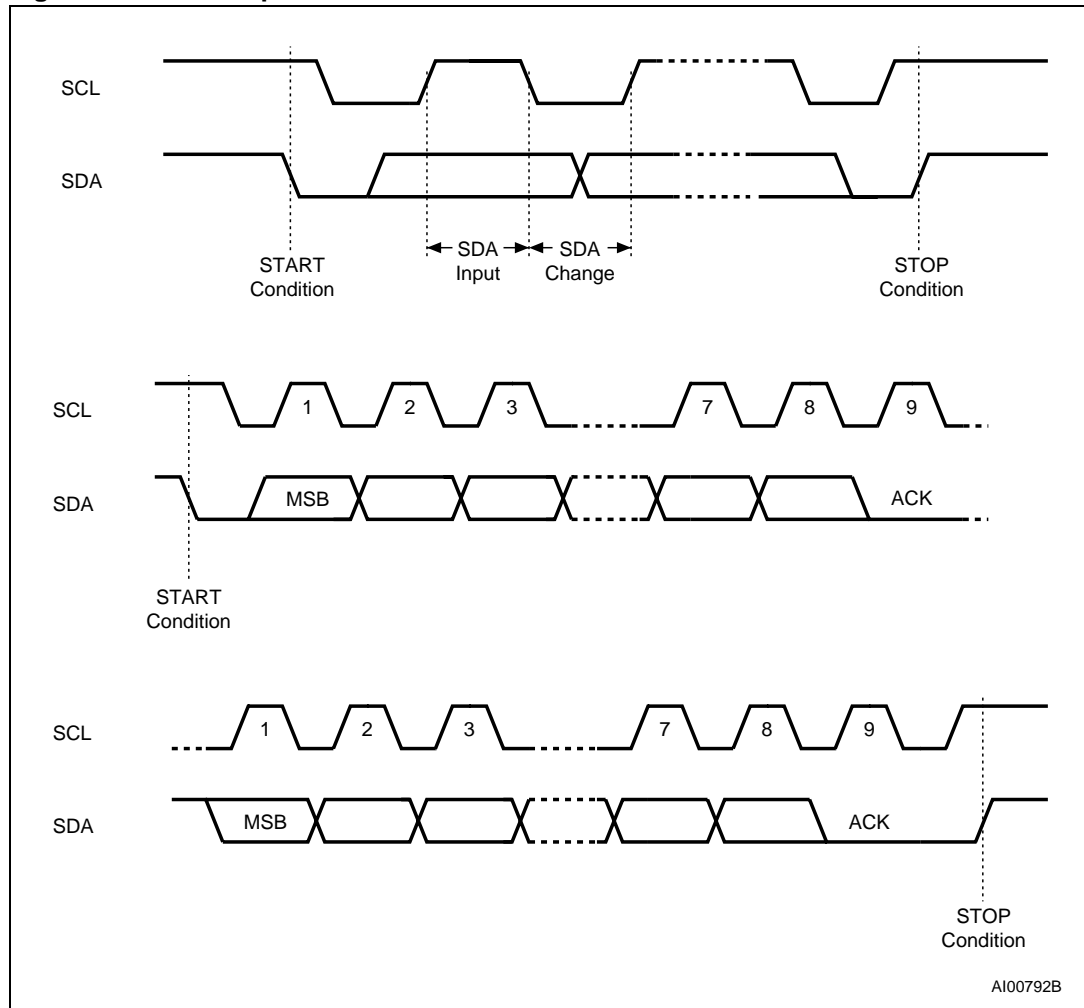

Table 3. Device select code

	Device Type Identifier ⁽¹⁾				Chip Enable Address ⁽²⁾			R \bar{W}
	b7	b6	b5	b4	b3	b2	b1	b0
Device Select Code	1	0	1	0	E2	E1	E0	R \bar{W}

1. The most significant bit, b7, is sent first.

2. E0, E1 and E2 are compared against the respective external pins on the memory device.

Table 4. Address most significant byte

b15	b14	b13	b12	b11	b10	b9	b8
-----	-----	-----	-----	-----	-----	----	----

Table 5. Address least significant byte

b7	b6	b5	b4	b3	b2	b1	b0
----	----	----	----	----	----	----	----

3 Memory organization

The memory is organized as shown in [Figure 6](#).

Figure 6. Block diagram

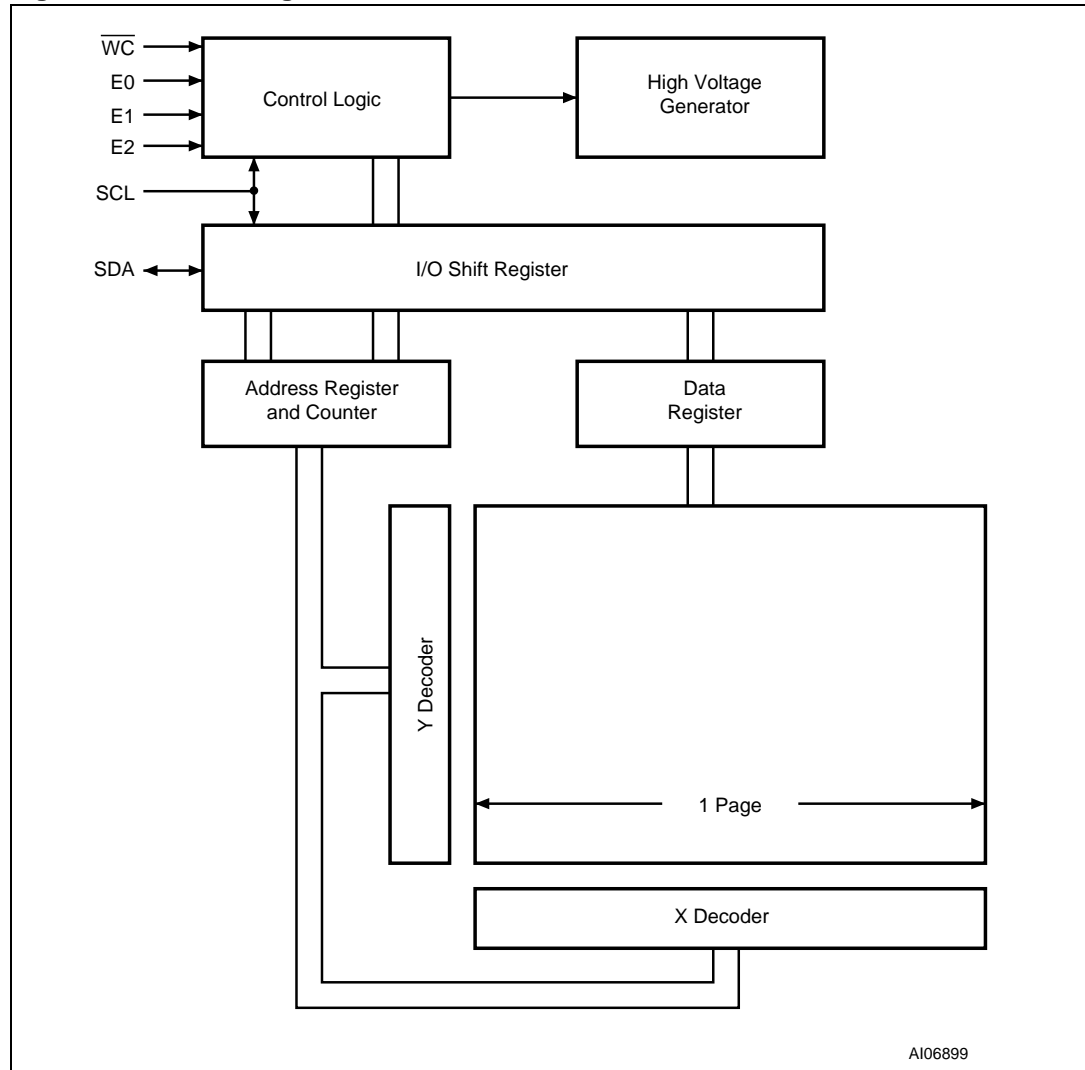

4 Device operation

The device supports the I²C protocol. This is summarized in [Figure 5](#). Any device that sends data on to the bus is defined to be a transmitter, and any device that reads the data to be a receiver. The device that controls the data transfer is known as the bus master, and the other as the slave device. A data transfer can only be initiated by the bus master, which will also provide the serial clock for synchronization. The M24C32, M24C64 and M24128 devices are always slaves in all communications.

4.1 Start condition

Start is identified by a falling edge of Serial Data (SDA) while Serial Clock (SCL) is stable in the High state. A Start condition must precede any data transfer command. The device continuously monitors (except during a Write cycle) Serial Data (SDA) and Serial Clock (SCL) for a Start condition, and will not respond unless one is given.

4.2 Stop condition

Stop is identified by a rising edge of Serial Data (SDA) while Serial Clock (SCL) is stable and driven High. A Stop condition terminates communication between the device and the bus master. A Read command that is followed by NoAck can be followed by a Stop condition to force the device into the Stand-by mode. A Stop condition at the end of a Write command triggers the internal Write cycle.

4.3 Acknowledge bit (ACK)

The acknowledge bit is used to indicate a successful byte transfer. The bus transmitter, whether it be bus master or slave device, releases Serial Data (SDA) after sending eight bits of data. During the 9th clock pulse period, the receiver pulls Serial Data (SDA) Low to acknowledge the receipt of the eight data bits.

4.4 Data Input

During data input, the device samples Serial Data (SDA) on the rising edge of Serial Clock (SCL). For correct device operation, Serial Data (SDA) must be stable during the rising edge of Serial Clock (SCL), and the Serial Data (SDA) signal must change *only* when Serial Clock (SCL) is driven Low.

4.5 Memory addressing

To start communication between the bus master and the slave device, the bus master must initiate a Start condition. Following this, the bus master sends the Device Select Code, shown in [Table 3](#) (on Serial Data (SDA), most significant bit first).

The Device Select Code consists of a 4-bit Device Type Identifier, and a 3-bit Chip Enable "Address" (E2, E1, E0). To address the memory array, the 4-bit Device Type Identifier is 1010b.

Up to eight memory devices can be connected on a single I²C bus. Each one is given a unique 3-bit code on the Chip Enable (E0, E1, E2) inputs. When the Device Select Code is received, the device only responds if the Chip Enable Address is the same as the value on the Chip Enable (E0, E1, E2) inputs.

The 8th bit is the Read/Write bit (\overline{RW}). This bit is set to 1 for Read and 0 for Write operations.

If a match occurs on the Device Select code, the corresponding device gives an acknowledgment on Serial Data (SDA) during the 9th bit time. If the device does not match the Device Select code, it deselected itself from the bus, and goes into Stand-by mode.

Table 6. Operating modes

Mode	\overline{RW} bit	$\overline{WC}^{(1)}$	Bytes	Initial Sequence
Current Address Read	1	X	1	START, Device Select, $\overline{RW} = 1$
Random Address Read	0	X	1	START, Device Select, $\overline{RW} = 0$, Address
	1	X		reSTART, Device Select, $\overline{RW} = 1$
Sequential Read	1	X	≥ 1	Similar to Current or Random Address Read
Byte Write	0	V_{IL}	1	START, Device Select, $\overline{RW} = 0$
Page Write	0	V_{IL}	≤ 32 for M24C64 and M24C32	START, Device Select, $\overline{RW} = 0$
			≤ 64 for M24128	

1. X = V_{IH} or V_{IL} .

Figure 7. Write mode sequences with $\overline{WC} = 1$ (data write inhibited)

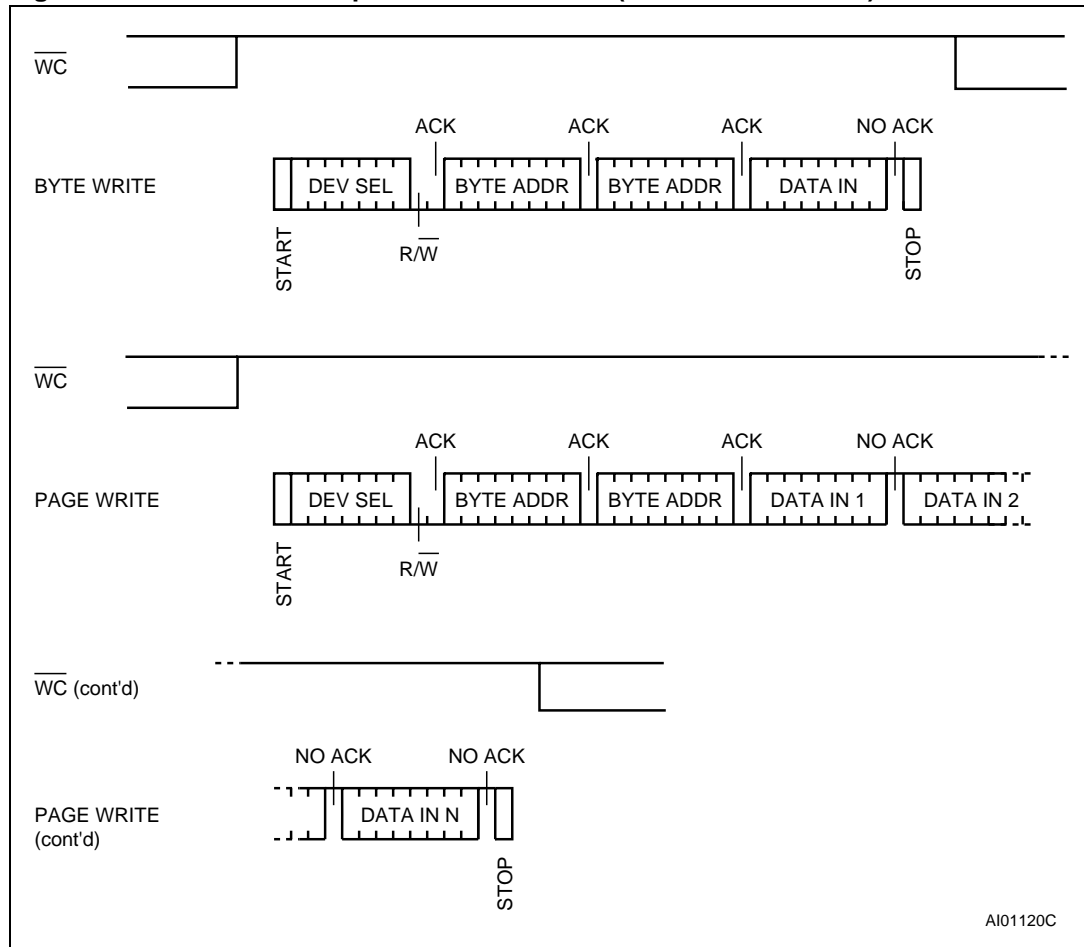

4.6 Write operations

Following a Start condition the bus master sends a Device Select Code with the Read/Write bit (RW) reset to 0. The device acknowledges this, as shown in [Figure 8](#), and waits for two address bytes. The device responds to each address byte with an acknowledge bit, and then waits for the data Byte.

Writing to the memory may be inhibited if Write Control (\overline{WC}) is driven High. Any Write instruction with Write Control (\overline{WC}) driven High (during a period of time from the Start condition until the end of the two address bytes) will not modify the memory contents, and the accompanying data bytes are *not* acknowledged, as shown in [Figure 7](#).

Each data byte in the memory has a 16-bit (two byte wide) address. The Most Significant Byte ([Table 4](#)) is sent first, followed by the Least Significant Byte ([Table 5](#)). Bits b15 to b0 form the address of the byte in memory.

When the bus master generates a Stop condition immediately after the Ack bit (in the “10th bit” time slot), either at the end of a Byte Write or a Page Write, the internal Write cycle is triggered. A Stop condition at any other time slot does not trigger the internal Write cycle.

After the Stop condition, the delay t_{w} , and the successful completion of a Write operation, the device's internal address counter is incremented automatically, to point to the next byte address after the last one that was modified.

During the internal Write cycle, Serial Data (SDA) is disabled internally, and the device does not respond to any requests.

4.7 Byte Write

After the Device Select code and the address bytes, the bus master sends one data byte. If the addressed location is Write-protected, by Write Control (\overline{WC}) being driven High, the device replies with NoAck, and the location is not modified. If, instead, the addressed location is not Write-protected, the device replies with Ack. The bus master terminates the transfer by generating a Stop condition, as shown in [Figure 8](#).

4.8 Page Write

The Page Write mode allows up to 32 bytes (for the M24C32 and M24C64) or 64 bytes (for the M24128) to be written in a single Write cycle, provided that they are all located in the same 'row' in the memory: that is, the most significant memory address bits (b13-b6 for M24128, b12-b5 for M24C64, and b11-b5 for M24C32) are the same. If more bytes are sent than will fit up to the end of the row, a condition known as 'roll-over' occurs. This should be avoided, as data starts to become overwritten in an implementation dependent way.

The bus master sends from 1 to 32 bytes of data (for the M24C32 and M24C64) or 64 bytes of data (for the M24128), each of which is acknowledged by the device if Write Control (\overline{WC}) is Low. If Write Control (\overline{WC}) is High, the contents of the addressed memory location are not modified, and each data byte is followed by a NoAck. After each byte is transferred, the internal byte address counter (inside the page) is incremented. The transfer is terminated by the bus master generating a Stop condition.

Figure 8. Write mode sequences with $\overline{WC} = 0$ (data write enabled)

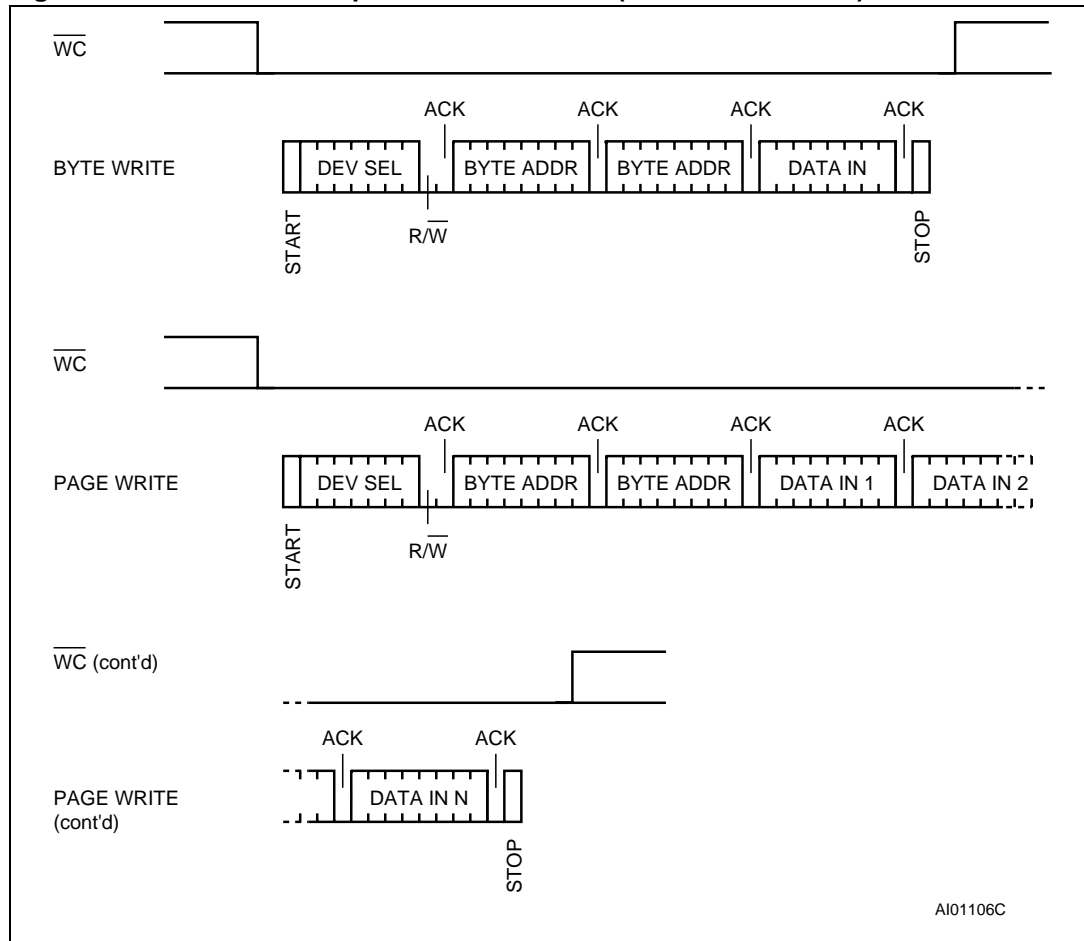
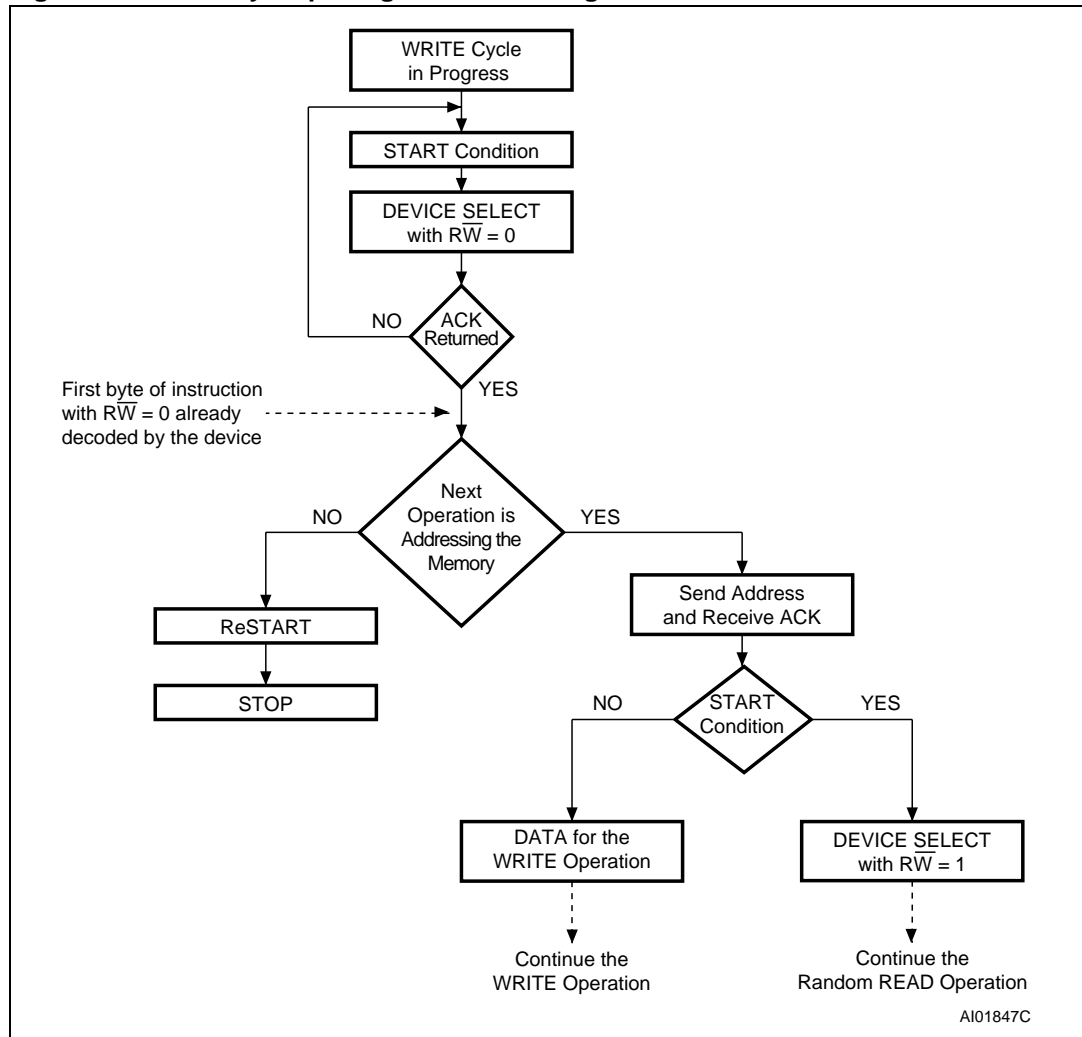

Figure 9. Write cycle polling flowchart using ACK



4.9 Minimizing system delays by polling on ACK

During the internal Write cycle, the device disconnects itself from the bus, and writes a copy of the data from its internal latches to the memory cells. The maximum Write time (t_w) is shown in [Table 17](#) and [Table 18](#), but the typical time is shorter. To make use of this, a polling sequence can be used by the bus master.

The sequence, as shown in [Figure 9](#), is:

- Initial condition: a Write cycle is in progress.
- Step 1: the bus master issues a Start condition followed by a Device Select Code (the first byte of the new instruction).
- Step 2: if the device is busy with the internal Write cycle, no Ack will be returned and the bus master goes back to Step 1. If the device has terminated the internal Write cycle, it responds with an Ack, indicating that the device is ready to receive the second part of the instruction (the first byte of this instruction having been sent during Step 1).

Figure 10. Read mode sequences

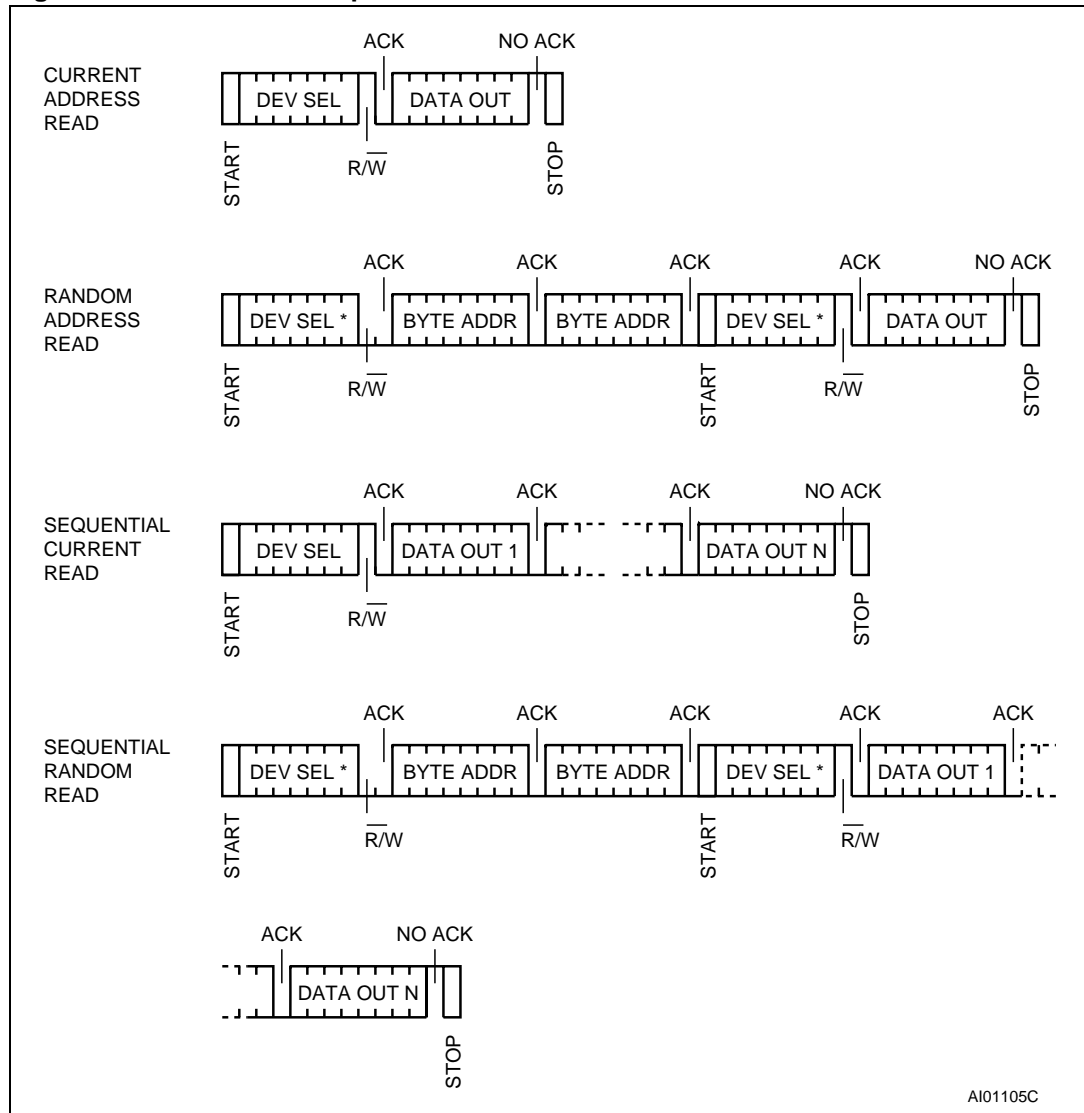

1. The seven most significant bits of the Device Select Code of a Random Read (in the 1st and 4th bytes) must be identical.

4.10 Read operations

Read operations are performed independently of the state of the Write Control (\overline{WC}) signal. After the successful completion of a Read operation, the device's internal address counter is incremented by one, to point to the next byte address.

4.11 Random Address Read

A dummy Write is first performed to load the address into this address counter (as shown in [Figure 10](#)) but *without* sending a Stop condition. Then, the bus master sends another Start condition, and repeats the Device Select Code, with the Read/Write bit (\overline{RW}) set to 1. The device acknowledges this, and outputs the contents of the addressed byte. The bus master must *not* acknowledge the byte, and terminates the transfer with a Stop condition.

4.12 Current Address Read

For the Current Address Read operation, following a Start condition, the bus master only sends a Device Select Code with the Read/Write bit (\overline{RW}) set to 1. The device acknowledges this, and outputs the byte addressed by the internal address counter. The counter is then incremented. The bus master terminates the transfer with a Stop condition, as shown in [Figure 10](#), *without* acknowledging the Byte.

4.13 Sequential Read

This operation can be used after a Current Address Read or a Random Address Read. The bus master *does* acknowledge the data byte output, and sends additional clock pulses so that the device continues to output the next byte in sequence. To terminate the stream of bytes, the bus master must *not* acknowledge the last byte, and *must* generate a Stop condition, as shown in [Figure 10](#).

The output data comes from consecutive addresses, with the internal address counter automatically incremented after each byte output. After the last memory address, the address counter 'rolls-over', and the device continues to output data from memory address 00h.

4.14 Acknowledge in Read mode

For all Read commands, the device waits, after each byte read, for an acknowledgment during the 9th bit time. If the bus master does not drive Serial Data (SDA) Low during this time, the device terminates the data transfer and switches to its Stand-by mode.

5 Initial delivery state

The device is delivered with all bits in the memory array set to 1 (each byte contains FFh).

6 Maximum rating

Stressing the device outside the ratings listed in [Table 7](#) may cause permanent damage to the device. These are stress ratings only, and operation of the device at these, or any other conditions outside those indicated in the Operating sections of this specification, is not implied. Exposure to Absolute Maximum Rating conditions for extended periods may affect device reliability. Refer also to the STMicroelectronics SURE Program and other relevant quality documents.

Table 7. Absolute maximum ratings

Symbol	Parameter	Min.	Max.	Unit
T_A	Ambient Operating Temperature	-40	130	°C
T_{STG}	Storage Temperature	-65	150	°C
T_{LEAD}	Lead Temperature during Soldering	see note ⁽¹⁾		°C
	PDIP-Specific Lead Temperature during Soldering		260 ⁽²⁾	°C
V_{IO}	Input or Output range	-0.50	6.5	V
V_{CC}	Supply Voltage	-0.50	6.5	V
V_{ESD}	Electrostatic Discharge Voltage (Human Body model) ⁽³⁾	-4000	4000	V

1. Compliant with JEDEC Std J-STD-020C (for small body, Sn-Pb or Pb assembly), the ST ECOPACK® 7191395 specification, and the European directive on Restrictions on Hazardous Substances (RoHS) 2002/95/EU.
2. T_{LEAD} max must not be applied for more than 10s.
3. AEC-Q100-002 (compliant with JEDEC Std JESD22-A114A, C1=100pF, R1=1500Ω, R2=500Ω)

7 DC and AC parameters

This section summarizes the operating and measurement conditions, and the DC and AC characteristics of the device. The parameters in the DC and AC Characteristic tables that follow are derived from tests performed under the Measurement Conditions summarized in the relevant tables. Designers should check that the operating conditions in their circuit match the measurement conditions when relying on the quoted parameters.

Table 8. Operating conditions (M24128-BW, M24C64-W, M24C32-W)

Symbol	Parameter	Min.	Max.	Unit
V_{CC}	Supply Voltage	2.5	5.5	V
T_A	Ambient Operating Temperature (Device Grade 6)	-40	85	°C
	Ambient Operating Temperature (Device Grade 3)	-40	125	°C

Table 9. Operating conditions (M24128-BR, M24C64-R, M24C32-R)

Symbol	Parameter	Min.	Max.	Unit
V_{CC}	Supply Voltage	1.8	5.5	V
T_A	Ambient Operating Temperature	-40	85	°C

Table 10. Operating conditions (M24C64-F, M24C32-F)

Symbol	Parameter	Min.	Max.	Unit
V_{CC}	Supply Voltage	1.7	5.5	V
T_A	Ambient Operating Temperature	-20	85	°C

Table 11. AC test measurement conditions

Symbol	Parameter	Min.	Max.	Unit
C_L	Load Capacitance	100		pF
	Input Rise and Fall Times		50	ns
	Input Levels	0.2 V_{CC} to 0.8 V_{CC}		V
	Input and Output Timing Reference Levels	0.3 V_{CC} to 0.7 V_{CC}		V

Figure 11. AC test measurement I/O waveform

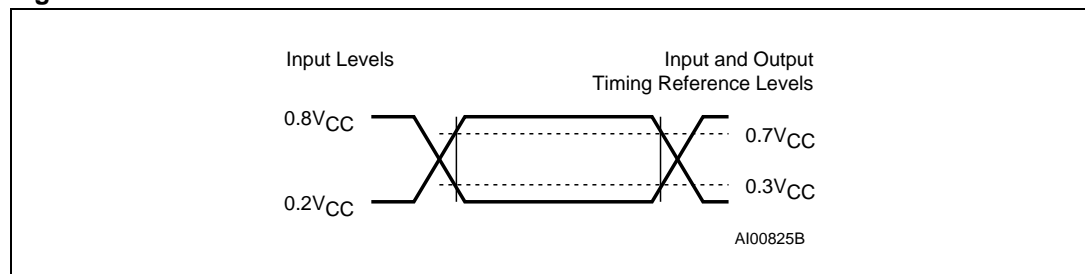

Table 12. Input parameters

Symbol	Parameter ^{(1),(2)}	Test Condition	Min.	Max.	Unit
C _{IN}	Input Capacitance (SDA)			8	pF
C _{IN}	Input Capacitance (other pins)			6	pF
Z _{WCL}	\overline{WC} Input Impedance	V _{IN} < 0.3V _{CC}	50	200	kΩ
Z _{WCH}	\overline{WC} Input Impedance	V _{IN} > 0.7V _{CC}	500		kΩ
t _{NS}	Pulse width ignored (Input Filter on SCL and SDA)			200	ns

1. T_A = 25°C, f = 400kHz
2. Sampled only, not 100% tested.

Table 13. DC characteristics (V_{CC} = 2.5V to 5.5V, device grade 6)

Symbol	Parameter	Test Condition (in addition to those in Table 8)	Min.	Max.	Unit
I _{LI}	Input Leakage Current (SCL, SDA, E2, E1, E0)	V _{IN} = V _{SS} or V _{CC} device in Stand-by mode		± 2	μA
I _{LO}	Output Leakage Current	V _{OUT} = V _{SS} or V _{CC} , SDA in Hi-Z		± 2	μA
I _{CC}	Supply Current (Read)	2.5V < V _{CC} < 5.5V, f _c =400kHz (rise/fall time < 30ns)		2	mA
I _{CC0}	Supply Current (Write)	During t _W , 2.5V < V _{CC} < 5.5V		5 ⁽¹⁾	mA
I _{CC1}	Stand-by Supply Current	V _{IN} = V _{SS} or V _{CC} , V _{CC} = 5.5V		5	μA
	Stand-by Supply Current	V _{IN} = V _{SS} or V _{CC} , V _{CC} = 2.5V		2	μA
V _{IL}	Input Low Voltage (SDA, SCL, \overline{WC})		-0.45	0.3V _{CC}	V
V _{IH}	Input High Voltage (SDA, SCL, \overline{WC})		0.7V _{CC}	V _{CC} +1	V
V _{OL}	Output Low Voltage	I _{OL} = 2.1mA, V _{CC} = 2.5V or I _{OL} = 3mA, V _{CC} = 5.5V		0.4	V

1. Characterized value, not tested in production.

Table 14. DC characteristics ($V_{CC} = 2.5V$ to $5.5V$, device grade 3)

Symbol	Parameter	Test Condition (in addition to those in Table 8)	Min.	Max.	Unit
I_{LI}	Input Leakage Current (SCL, SDA, E2, E1, E0)	$V_{IN} = V_{SS}$ or V_{CC} device in Stand-by mode		± 2	μA
I_{LO}	Output Leakage Current	$V_{OUT} = V_{SS}$ or V_{CC} , SDA in Hi-Z		± 2	μA
I_{CC}	Supply Current (Read)	$2.5V < V_{CC} < 5.5V$, $f_c=400kHz$ (rise/fall time $< 30ns$)		2	mA
I_{CC0}	Supply Current (Write)	During t_{W} , $2.5V < V_{CC} < 5.5V$		5 ⁽¹⁾	mA
I_{CC1}	Stand-by Supply Current	$V_{IN} = V_{SS}$ or V_{CC} , $2.5V < V_{CC} < 5.5V$		10	μA
V_{IL}	Input Low Voltage (SDA, SCL, \overline{WC})		-0.45	$0.3V_{CC}$	V
V_{IH}	Input High Voltage (SDA, SCL, \overline{WC})		$0.7V_{CC}$	$V_{CC}+1$	V
V_{OL}	Output Low Voltage	$I_{OL} = 2.1mA$, $V_{CC} = 2.5V$ or $I_{OL} = 3mA$, $V_{CC} = 5.5V$		0.4	V

1. Characterized value, not tested in production.

Table 15. DC characteristics ($V_{CC} = 1.8V$ to $5.5V$)

Symbol	Parameter	Test Condition (in addition to those in Table 9)	Min.	Max.	Unit
I_{LI}	Input Leakage Current (SCL, SDA, E2, E1, E0)	$V_{IN} = V_{SS}$ or V_{CC} device in Stand-by mode		± 2	μA
I_{LO}	Output Leakage Current	$V_{OUT} = V_{SS}$ or V_{CC} , SDA in Hi-Z		± 2	μA
I_{CC}	Supply Current (Read)	$V_{CC} = 1.8V$, $f_c = 400kHz$ (rise/fall time $< 30ns$)		0.8	mA
I_{CC0}	Supply Current (Write)	During t_{W} , $1.8V < V_{CC} < 2.5V$		3 ⁽¹⁾	mA
I_{CC1}	Stand-by Supply Current	$V_{IN} = V_{SS}$ or V_{CC} , $1.8V < V_{CC} < 2.5V$		1	μA
V_{IL}	Input Low Voltage (SDA, SCL, \overline{WC})		-0.45	$0.3 V_{CC}$	V
V_{IH}	Input High Voltage (SDA, SCL, \overline{WC})		$0.7V_{CC}$	$V_{CC}+1$	V
V_{OL}	Output Low Voltage	$I_{OL} = 0.7 mA$, $V_{CC} = 1.8 V$		0.2	V

1. Characterized value, not tested in production.

Table 16. DC characteristics ($V_{CC} = 1.7V$ to $5.5V$)⁽¹⁾

Symbol	Parameter	Test Condition (in addition to those in Table 10)	Min.	Max.	Unit
I_{LI}	Input Leakage Current (SCL, SDA, E2, E1, E0)	$V_{IN} = V_{SS}$ or V_{CC} device in Stand-by mode		± 2	μA
I_{LO}	Output Leakage Current	$V_{OUT} = V_{SS}$ or V_{CC} , SDA in Hi-Z		± 2	μA
I_{CC}	Supply Current (Read)	$V_{CC} = 1.7V$, $f_c = 400kHz$ (rise/fall time < 30ns)		0.8	mA
I_{CC0}	Supply Current (Write)	During t_W , $1.7V < V_{CC} < 2.5V$		3 ⁽²⁾	mA
I_{CC1}	Stand-by Supply Current	$V_{IN} = V_{SS}$ or V_{CC} , $1.7V < V_{CC} < 2.5V$		1	μA
V_{IL}	Input Low Voltage (SDA, SCL, \overline{WC})		-0.45	$0.3 V_{CC}$	V
V_{IH}	Input High Voltage (SDA, SCL, \overline{WC})		$0.7V_{CC}$	$V_{CC}+1$	V
V_{OL}	Output Low Voltage	$I_{OL} = 0.7 mA$, $V_{CC} = 1.7 V$		0.2	V

1. Preliminary data.

2. Characterized value, not tested in production.

Table 17. AC characteristics ($V_{CC} = 2.5V$ to $5.5V$, device grades 6 and 3)

Test conditions specified in Table 11 and Table 8					
Symbol	Alt.	Parameter	Min.	Max.	Unit
f_C	f_{SCL}	Clock Frequency		400	kHz
t_{CHCL}	t_{HIGH}	Clock Pulse Width High	600		ns
t_{CLCH}	t_{LOW}	Clock Pulse Width Low	1300		ns
$t_{DL1DL2}^{(1)}$	t_F	SDA Fall Time	20	300	ns
t_{DXCX}	$t_{SU:DAT}$	Data In Set Up Time	100		ns
t_{CLDX}	$t_{HD:DAT}$	Data In Hold Time	0		ns
t_{CLQX}	t_{DH}	Data Out Hold Time	200		ns
$t_{CLQV}^{(2)}$	t_{AA}	Clock Low to Next Data Valid (Access Time)	200	900	ns
$t_{CHDX}^{(3)}$	$t_{SU:STA}$	Start Condition Set Up Time	600		ns
t_{DLCL}	$t_{HD:STA}$	Start Condition Hold Time	600		ns
t_{CHDH}	$t_{SU:STO}$	Stop Condition Set Up Time	600		ns
t_{DHDL}	t_{BUF}	Time between Stop Condition and Next Start Condition	1300		ns
t_W	t_{WR}	Write Time		5	ms

1. Sampled only, not 100% tested.
2. To avoid spurious START and STOP conditions, a minimum delay is placed between SCL=1 and the falling or rising edge of SDA.
3. For a reSTART condition, or following a Write cycle.

Table 18. AC characteristics ($V_{CC} = 1.8V$ to $5.5V$ or $V_{CC} = 1.7V$ to $5.5V$)

Test conditions specified in Table 11 and Table 9 or Table 10					
Symbol	Alt.	Parameter	Min.	Max.	Unit
f_C	f_{SCL}	Clock Frequency		400	kHz
t_{CHCL}	t_{HIGH}	Clock Pulse Width High	600		ns
t_{CLCH}	t_{LOW}	Clock Pulse Width Low	1300		ns
$t_{DL1DL2}^{(1)}$	t_F	SDA Fall Time	20	300	ns
t_{DXCX}	$t_{SU:DAT}$	Data In Set Up Time	100		ns
t_{CLDX}	$t_{HD:DAT}$	Data In Hold Time	0		ns
t_{CLQX}	t_{DH}	Data Out Hold Time	200		ns
$t_{CLQV}^{(2)}$	t_{AA}	Clock Low to Next Data Valid (Access Time)	200	900	ns
$t_{CHDX}^{(3)}$	$t_{SU:STA}$	Start Condition Set Up Time	600		ns
t_{DLCL}	$t_{HD:STA}$	Start Condition Hold Time	600		ns
t_{CHDH}	$t_{SU:STO}$	Stop Condition Set Up Time	600		ns
t_{DHDL}	t_{BUF}	Time between Stop Condition and Next Start Condition	1300		ns
t_W	t_{WR}	Write Time		10	ms

1. Sampled only, not 100% tested.
2. To avoid spurious START and STOP conditions, a minimum delay is placed between SCL=1 and the falling or rising edge of SDA.
3. For a reSTART condition, or following a Write cycle.

Figure 12. AC waveforms

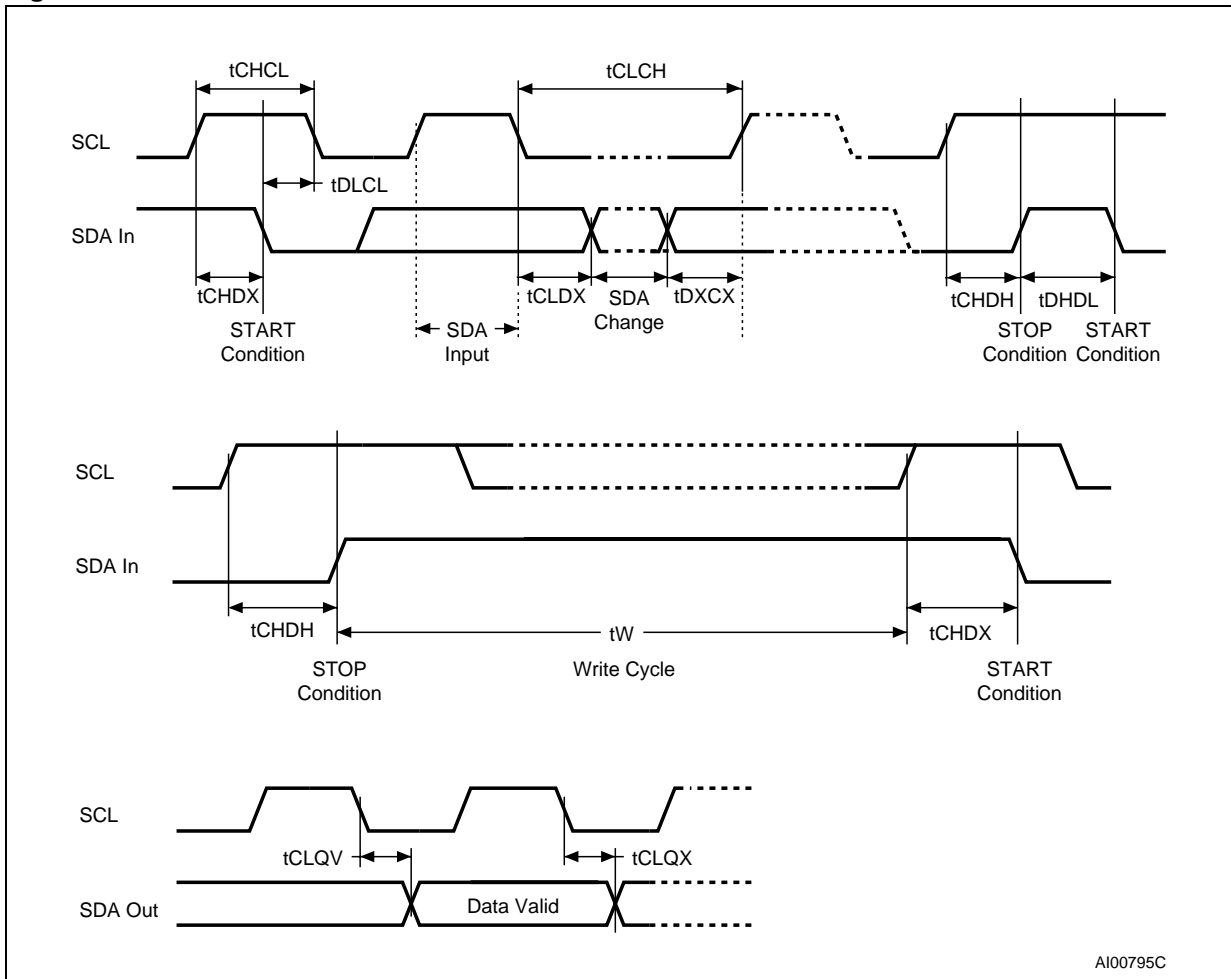

AI00795C

8 Package mechanical

Figure 13. PDIP8 – 8 pin Plastic DIP, 0.25mm lead frame, package outline

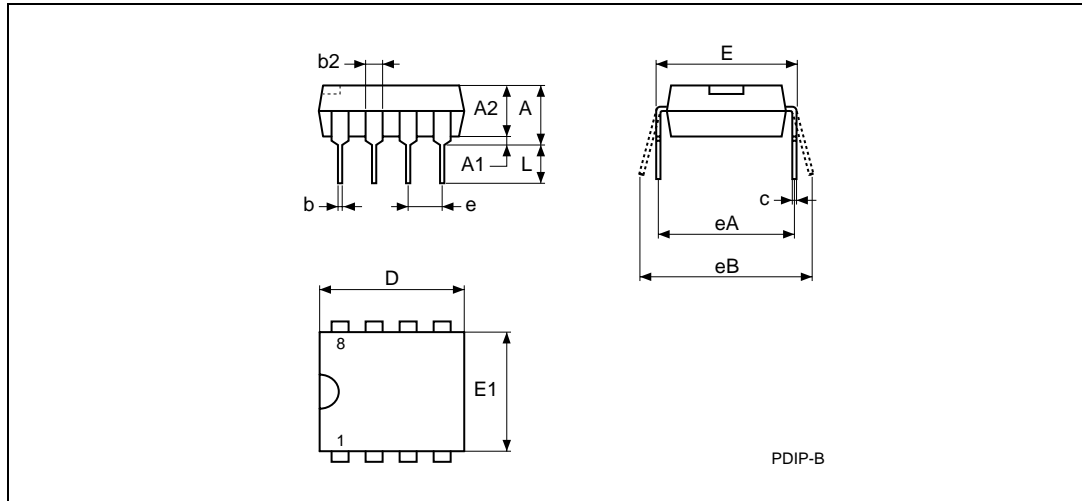

1. Drawing is not to scale.

Table 19. PDIP8 – 8 pin Plastic DIP, 0.25mm lead frame, package mechanical data

Symbol	millimeters			inches		
	Typ.	Min.	Max.	Typ.	Min.	Max.
A			5.33			0.210
A1		0.38			0.015	
A2	3.30	2.92	4.95	0.130	0.115	0.195
b	0.46	0.36	0.56	0.018	0.014	0.022
b2	1.52	1.14	1.78	0.060	0.045	0.070
c	0.25	0.20	0.36	0.010	0.008	0.014
D	9.27	9.02	10.16	0.365	0.355	0.400
E	7.87	7.62	8.26	0.310	0.300	0.325
E1	6.35	6.10	7.11	0.250	0.240	0.280
e	2.54	–	–	0.100	–	–
eA	7.62	–	–	0.300	–	–
eB			10.92			0.430
L	3.30	2.92	3.81	0.130	0.115	0.150

Figure 14. SO8 narrow – 8 lead Plastic Small Outline, 150 mils body width, package outline

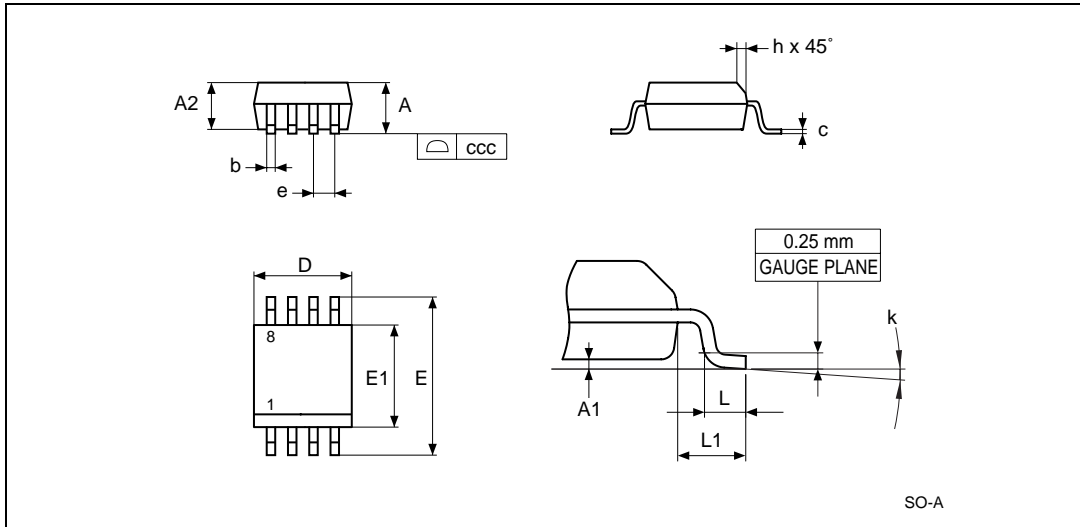

1. Drawing is not to scale.

Table 20. SO8 narrow – 8 lead Plastic Small Outline, 150 mils body width, package mechanical data

Symbol	millimeters			inches		
	Typ	Min	Max	Typ	Min	Max
A			1.75			0.069
A1		0.10	0.25		0.004	0.010
A2		1.25			0.049	
b		0.28	0.48		0.011	0.019
c		0.17	0.23		0.007	0.009
ccc			0.10			0.004
D	4.90	4.80	5.00	0.193	0.189	0.197
E	6.00	5.80	6.20	0.236	0.228	0.244
E1	3.90	3.80	4.00	0.154	0.150	0.157
e	1.27	–	–	0.050	–	–
h		0.25	0.50		0.010	0.020
k		0°	8°		0°	8°
L		0.40	1.27		0.016	0.050
L1	1.04			0.041		

Figure 15. TSSOP8 – 8 lead Thin Shrink Small Outline, package outline

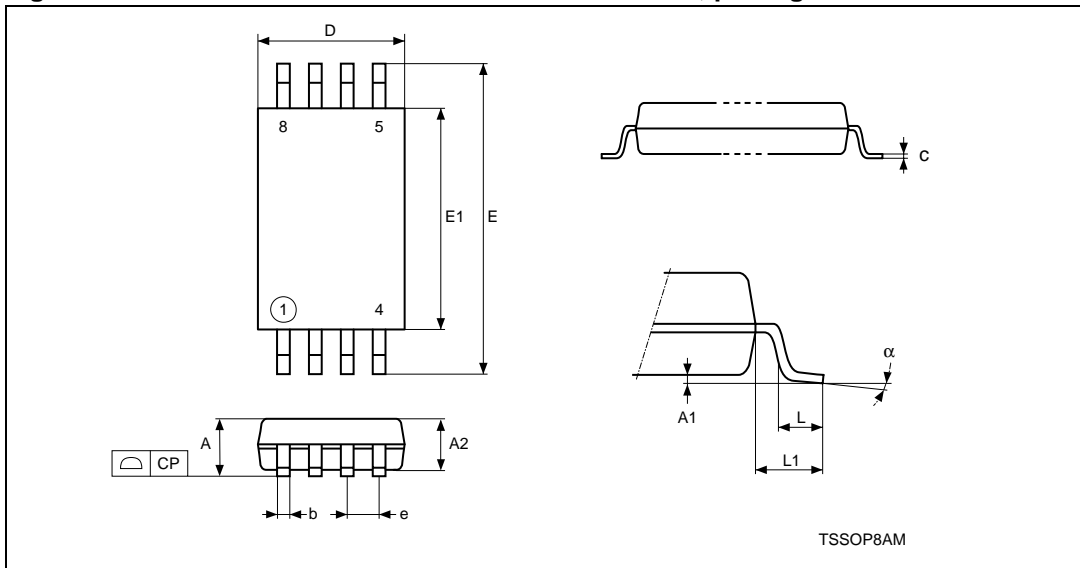

1. Drawing is not to scale.

Table 21. TSSOP8 – 8 lead Thin Shrink Small Outline, package mechanical data

Symbol	millimeters			inches		
	Typ.	Min.	Max.	Typ.	Min.	Max.
A			1.200			0.0472
A1		0.050	0.150		0.0020	0.0059
A2	1.000	0.800	1.050	0.0394	0.0315	0.0413
b		0.190	0.300		0.0075	0.0118
c		0.090	0.200		0.0035	0.0079
CP			0.100			0.0039
D	3.000	2.900	3.100	0.1181	0.1142	0.1220
e	0.650	–	–	0.0256	–	–
E	6.400	6.200	6.600	0.2520	0.2441	0.2598
E1	4.400	4.300	4.500	0.1732	0.1693	0.1772
L	0.600	0.450	0.750	0.0236	0.0177	0.0295
L1	1.000			0.0394		
α		0°	8°		0°	8°

Figure 16. UFDFPN8 (MLP8) – 8-lead Ultra thin Fine pitch Dual Flat Package No lead 2 x 3mm, package outline

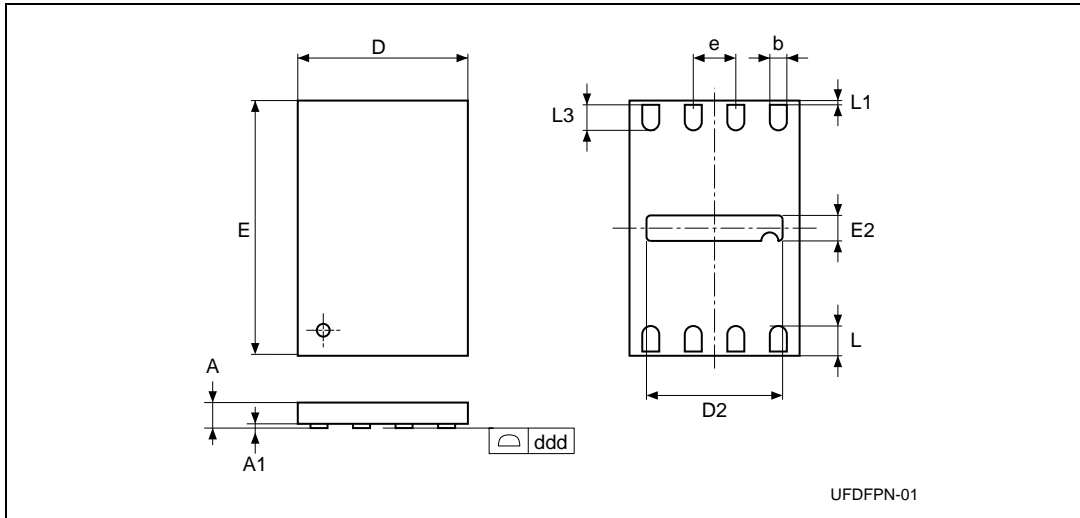

1. Drawing is not to scale.

Table 22. UFDFPN8 (MLP8) – 8-lead Ultra thin Fine pitch Dual Flat Package No lead 2 x 3mm, package mechanical data

Symbol	millimeters			inches		
	Typ	Min	Max	Typ	Min	Max
A	0.55	0.50	0.60	0.022	0.020	0.024
A1	0.02	0.00	0.05	0.001	0.000	0.002
b	0.25	0.20	0.30	0.010	0.008	0.012
D	2.00	1.90	2.10	0.079	0.075	0.083
D2	1.60	1.50	1.70	0.063	0.059	0.067
ddd			0.08			0.003
E	3.00	2.90	3.10	0.118	0.114	0.122
E2	0.20	0.10	0.30	0.008	0.004	0.012
e	0.50	–	–	0.020	–	–
L	0.45	0.40	0.50	0.018	0.016	0.020
L1			0.15			0.006
L3		0.30			0.012	

9 Part numbering

Table 23. Ordering information scheme

Example:	M24C32-	W	MN	6	T	P	/B
Device Type M24 = I ² C serial access EEPROM							
Device Function 128-B = 128 Kbit (16384 x 8) C64- = 64 Kbit (8192 x 8) C32- = 32 Kbit (4096 x 8)							
Operating Voltage W = V _{CC} = 2.5 to 5.5V R = V _{CC} = 1.8 to 5.5V F = V _{CC} = 1.7 to 5.5V ⁽¹⁾							
Package BN = PDIP8 MN = SO8 (150 mil width) DW = TSSOP8 (169 mil width) MB = UFDFPN8 (MLP8) ⁽²⁾							
Device Grade 6 = Industrial: device tested with standard test flow over -40 to 85 °C 3 = Automotive: device tested with High Reliability Certified Flow ⁽³⁾ over -40 to 125°C. 5 = Consumer: device tested with standard test flow over -20 to 85°C ⁽¹⁾							
Option blank = Standard Packing T = Tape and Reel Packing							
Plating Technology blank = Standard SnPb plating P or G = ECOPACK® (RoHS compliant)							
Process B = F6DP26% Rousset P = F6DP26% Chartered							

1. Device grade 5 is available only with the operating voltage option F.
2. The UFDFPN8 package is available in M24C32-x devices only. It is not available in M24C64-x devices.
3. ST strongly recommends the use of the Automotive Grade devices for use in an automotive environment. The High Reliability Certified Flow (HRCF) is described in the quality note QNEE9801. Please ask your nearest ST sales office for a copy.

For a list of available options (speed, package, etc.) or for further information on any aspect of this device, please contact your nearest ST Sales Office.

The category of Second Level Interconnect is marked on the package and on the inner box label, in compliance with JEDEC Standard JESD97. The maximum ratings related to soldering conditions are also marked on the inner box label.

10 Revision history

Table 24. Document revision history

Date	Revision	Changes
22-Dec-1999	2.3	TSSOP8 package in place of TSSOP14 (pp 1, 2, OrderingInfo, PackageMechData).
28-Jun-2000	2.4	TSSOP8 package data corrected
31-Oct-2000	2.5	References to Temperature Range 3 removed from Ordering Information Voltage range -S added, and range -R removed from text and tables throughout.
20-Apr-2001	2.6	Lead Soldering Temperature in the Absolute Maximum Ratings table amended Write Cycle Polling Flow Chart using ACK illustration updated References to PSDIP changed to PDIP and Package Mechanical data updated
16-Jan-2002	2.7	Test condition for I_{L1} made more precise, and value of I_{L1} for E2-E0 and WC added -R voltage range added
02-Aug-2002	2.8	Document reformatted using new template. TSSOP8 (3x3mm ² body size) package (MSOP8) added. 5ms write time offered for 5V and 2.5V devices
04-Feb-2003	2.9	SO8W package removed. -S voltage range removed
27-May-2003	2.10	TSSOP8 (3x3mm ² body size) package (MSOP8) removed
22-Oct-2003	3.0	Table of contents, and Pb-free options added. Minor wording changes in Summary Description, Power-On Reset, Memory Addressing, Write Operations, Read Operations. $V_{IL}(\min)$ improved to -0.45V.
01-Jun-2004	4.0	Absolute Maximum Ratings for $V_{IO}(\min)$ and $V_{CC}(\min)$ improved. Soldering temperature information clarified for RoHS compliant devices. Device Grade clarified
04-Nov-2004	5.0	Product List summary table added. Device Grade 3 added. 4.5-5.5V range is Not for New Design. Some minor wording changes. AEC-Q100-002 compliance. $t_{NS}(\max)$ changed. $V_{IL}(\min)$ is the same on all input pins of the device. Z_{WCL} changed.
05-Jan-2005	6.0	UFDFPN8 package added. Small text changes.

Table 24. Document revision history (continued)

Date	Revision	Changes
29-Jun-2006	7	<p>Document converted to new ST template.</p> <p>M24C32 and M24C64 products (4.5 to 5.5V supply voltage) removed. M24C64 and M24C32 products (1.7 to 5.5V supply voltage) added.</p> <p>Section 2.1: Chip Enable (E0, E1, E2) and Section 2.2: Write Control (WC) modified, Section 2.3: Supply voltage (VCC) added and replaces Power On Reset: VCC Lock-Out Write Protect section.</p> <p>T_A added, Note 1 updated and T_{LEAD} specified for PDIP packages in Table 7: Absolute maximum ratings.</p> <p>I_{CC0} added, I_{CC} voltage conditions changed and I_{CC1} specified over the whole voltage range in Table 13: DC characteristics (VCC = 2.5V to 5.5V, device grade 6).</p> <p>I_{CC0} added, I_{CC} frequency conditions changed and I_{CC1} specified over the whole voltage range in Table 15: DC characteristics (VCC = 1.8V to 5.5V).</p> <p>t_W modified in Table 17: AC characteristics (VCC = 2.5V to 5.5V, device grades 6 and 3).</p> <p>SO8N package specifications updated (see Figure 14 and Table 20).</p> <p>Device grade 5 added, B and P Process letters added to Table 23: Ordering information scheme. Small text changes.</p>
03-Jul-2006	8	<p>I_{CC1} modified in Table 13: DC characteristics (VCC = 2.5V to 5.5V, device grade 6).</p> <p>Note 1 added to Table 16: DC characteristics (VCC = 1.7V to 5.5V) and table title modified.</p>
17-Oct-2006	9	<p>UFDFPN8 package specifications updated (see Table 22). M24128-BW- and M24128-BR part numbers added.</p> <p>Generic part number corrected in Feature summary on page 1.</p> <p>I_{CC0} corrected in Table 14 and Table 13.</p> <p>Packages are ECOPACK® compliant.</p>