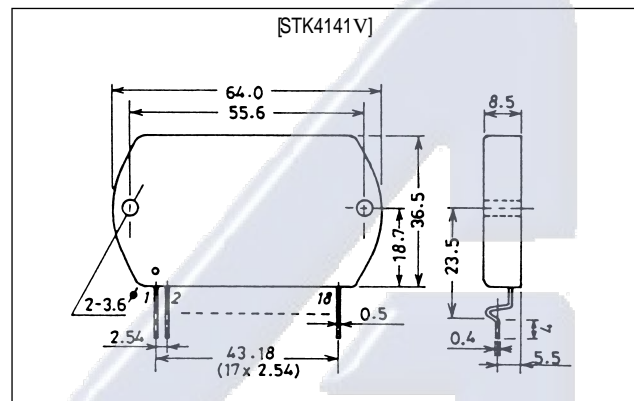

**STK4141V**
**AF Power Amplifier (Split Power Supply)**  
**(25W + 25W min, THD = 0.08%)**
**Features**

- The STK4102II series (THD=0.4%), STK4201V series (THD=0.08%) and STK4141X series (THD=0.02%) are pin-compatible. Once the PCB pattern is designed, you can easily satisfy the requirements for new sets simply by changing the IC.
- Built-in muting circuit to cut off various kinds of pop noise.
- Greatly reduced heat sink due to substrate temperature 125°C guaranteed.
- Current mirror circuit application reduces distortion to 0.08%.

**Package Dimensions**

unit: mm

**4040****Specifications****Maximum Ratings** at  $T_a = 25^\circ\text{C}$ 

Parameter	Symbol	Conditions	Ratings	Unit
Maximum supply voltage	$V_{CC \text{ max}}$		$\pm 40.5$	V
Thermal resistance	$\theta_{j-c}$		2.6	$^\circ\text{C/W}$
Junction temperature	$T_j$		150	$^\circ\text{C}$
Operating substrate temperature	$T_c$		125	$^\circ\text{C}$
Storage temperature	$T_{stg}$		-30 to +125	$^\circ\text{C}$
Available time for load short-circuit	$t_s$	$V_{CC} = \pm 27\text{V}$ , $R_L = 8\Omega$ , $f = 50\text{Hz}$ , $P_O = 25\text{W}$	2	s

**Recommended Operating Conditions** at  $T_a = 25^\circ\text{C}$ 

Parameter	Symbol	Conditions	Ratings	Unit
Recommended supply voltage	$V_{CC}$		$\pm 27.0$	V
Load resistance	$R_L$		8	$\Omega$

STK4141V

**Operating Characteristics** at  $T_a = 25^\circ\text{C}$ ,  $V_{CC} = \pm 27.0$ ,  $R_L = 8\Omega$ (non-inductive),  $R_g = 600\Omega$ ,  $V_G = 40\text{dB}$

Parameter	Symbol	Conditions	min	typ	max	Unit
Quiescent current	$I_{CCO}$	$V_{CC} = \pm 32.5\text{V}$	20	40	100	mA
Output power	$P_{O1}$	$f = 20\text{Hz to } 20\text{kHz}$ , $\text{THD} = 0.08\%$	25			W
	$P_{O2}$	$V_{CC} = \pm 24\text{V}$ , $f = 1\text{kHz}$ , $\text{THD} = 0.2\%$ , $R_L = 4\Omega$	25			W
Total harmonic distortion	THD	$f = 1\text{kHz}$ , $P_O = 1\text{W}$			0.08	%
Frequency response	$f_L, f_H$	$P_O = 1\text{W}$ , $+0$ $-3$ dB		20 to 50k		Hz
Input impedance	$r_i$	$f = 1\text{kHz}$ , $P_O = 1\text{W}$		55		$k\Omega$
Output noise voltage	$V_{NO}$	$V_{CC} = \pm 32.5\text{V}$ , $R_g = 10k\Omega$			1.2	mVrms
Neutral voltage	$V_N$	$V_{CC} = \pm 32.5\text{V}$	-70	0	+70	mV
Muting voltage	$V_M$		-2	-5	-10	V

Notes. For power supply at the time of test, use a constant-voltage power supply unless otherwise specified.  
For measurement of the available time for load short-circuit and output noise voltage, use the specified transformer power supply shown below.  
The output noise voltage is represented by the peak value on rms scale (VTVM) of average value indicating type. For AC power supply, use an AC stabilized power supply (50Hz) to eliminate the effect of flicker noise in AC primary line.

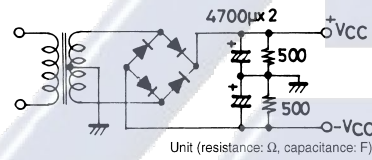

Specified Transformer Power Supply  
(Equivalent to RP-25)

**Equivalent Circuit**

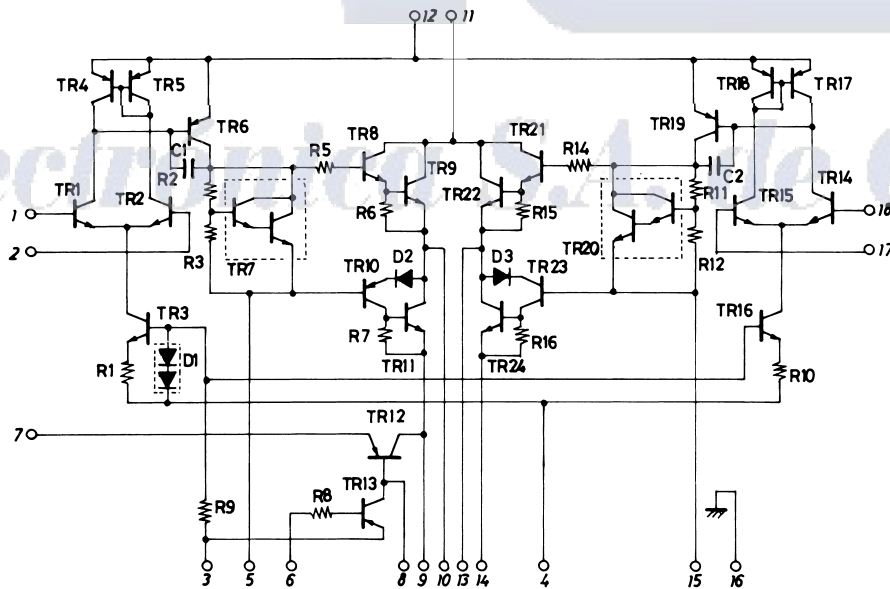



STK4141V

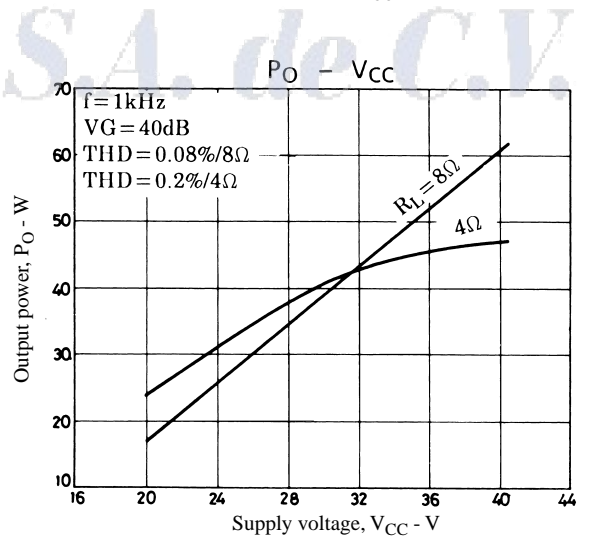
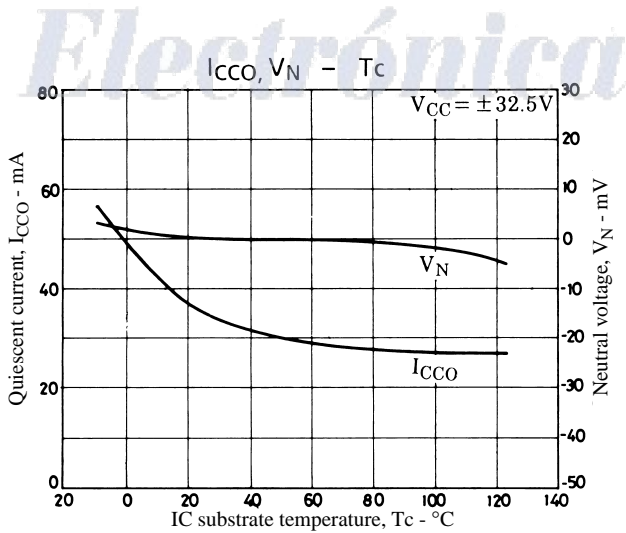
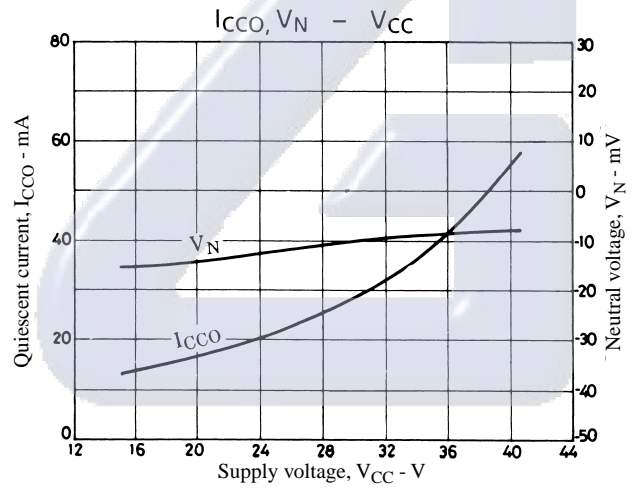
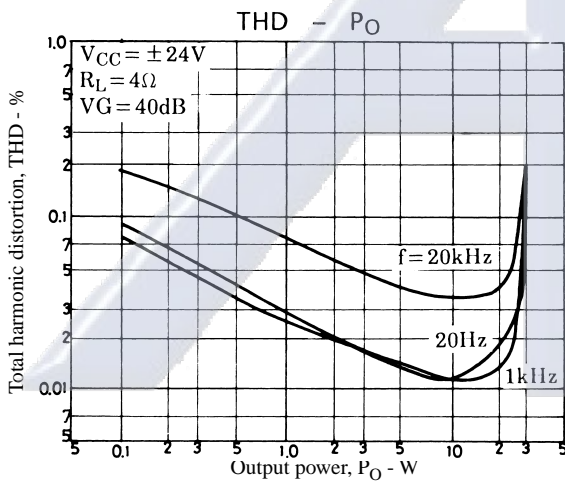
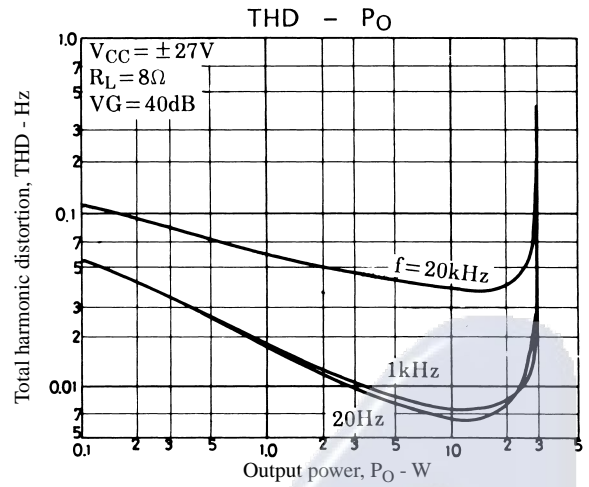
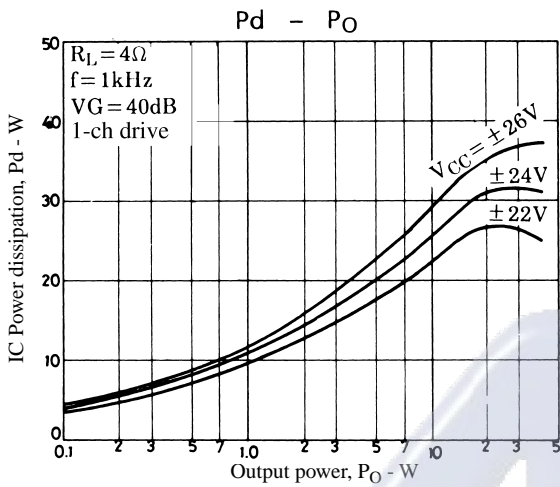

Electrónica S.A. de C.V.

STK4141V

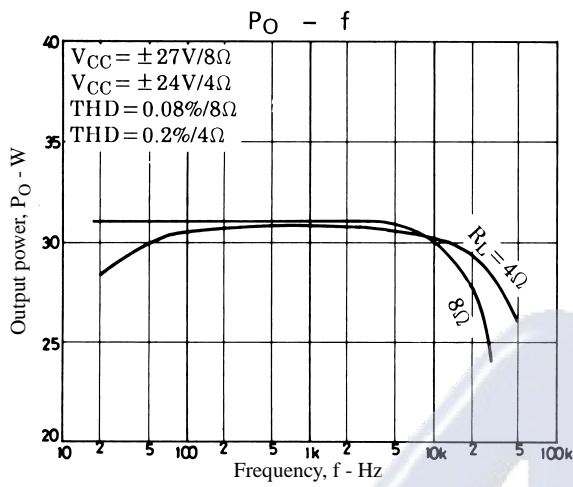

*Electrónica S.A. de C.V.*